

Power Quality Assessment in Real Shipboard Microgrid Systems under Unbalanced and Harmonic AC Bus Voltage

Wenzhao Liu¹, Tomasz. Tarasiuk², Mariusz. Gorniak², Josep M. Guerrero¹, Mehdi Savaghebi¹, Juan C. Vasquez¹, and Chun-Lien Su³

¹Department of energy technology, Aalborg University, Aalborg, Denmark
{wzl, joz, mes, juq}@et.aau.dk

²Department of marine electrical power engineering, Gdynia Maritime University, Gdynia, Poland
{t.tarasiuk, m.gorniak}@we.am.gdynia.pl

³Department of marine engineering, National Kaohsiung Marine University, Kaohsiung, Taiwan
cls@webmail.nkmu.edu.tw

Abstract—Power quality (PQ) becomes more and more pressing issue on shipboard microgrid systems (SMG). Especially, the impact of voltage unbalance combined with harmonic distortions on the SMG behaviors has not been well investigated before. For this paper, a series of controlled experimental investigations were proposed and carried out in a real ship under sea-going conditions to address this problem. The ship experimental results were presented and discussed considering non-linear bow thruster load and high power ballast pump loads under unbalanced and harmonic voltage conditions. In addition, the analysis of voltage transient dips during ballast pump starting up is presented. Further, the voltage/current distortions of working generator, bow thruster and pump loads are analyzed. The paper provides a valuable analysis for coping with PQ issues in the real ship power system.

Keywords—power quality; shipboard microgrid; unbalance; harmonic;

I. INTRODUCTION

Power Quality (PQ) issues for Shipboard Microgrid Systems (SMGs) are among the significant concerns with the power electronics applications onboard, especially concerning the wide use of variable frequency drives for loads such as: pumps, fans, bow thruster motors and propellers [1].

Unlike the terrestrial microgrid systems, the characteristics of the SMGs usually included generators with limited capacity, amount of nonlinear and pulsed loads with high power which are always hard to control but have more flexibility requirements [2]. The typical ship operates in different working modes to suite specific voyage conditions, with significantly varying PQ characteristics. Based on these characteristics, the SMGs are more prone to poor power quality, such as unbalances and harmonic voltage/current waveforms, high magnitude of transient disturbances and global frequency variations, which brings potential safety hazards to shipboard power services. All of these also lead to

the requirements for the PQ assessment and improvement onboard become more and more visible and efficient.

However, the analysis for the behaviors of the whole SMGs were still quite complex and especially under unbalanced and distorted conditions, most papers and standards were not fully investigated. In fact, there is a clear lack of requirements regarding voltage/current unbalances in the maritime rules of International Association of Classification Societies (IACS) and its members, except the IEEE Standard 45-2002, which requires that line to line voltage unbalance should not exceed 3% onboard [3]. Further, the consequences of voltage unbalance on generators and other electrical devices can be various, such as the damage of the auxiliary diesel engines by unbalanced distortions which may cause malfunctions to the bearings of the engine and forced the generator breakdown [4]. This may in turn cause overheating of the bearings when the generator cut in again [5] or significantly faster degradation of equipment insulation (thermal ageing), and result in failure and/or malfunctions in the real ship power systems [6-9].

In fact, every SMGs, even relatively small one, contains dozens or hundreds electrical devices working at the same time and supplied by voltage with fluctuating frequency and magnitude, located on pitching and rolling vessel [10], [11]. Therefore, the behaviors of SMGs can be hardly determined by calculations only, since the system very characteristic changes continuously over time and unpredictable number of interactions occurs. The problem of the PQ assessment validity is recognized by IACS, which requires that the level of harmonic distortion experienced onboard would be determined by calculations, but its “results and validity of the guidance provided are to be verified by the survey or during sea trials” [12].

Therefore, the main aim of this paper is try to fill the aforementioned gap and investigate the particular SMGs behavior in the presence of voltage unbalance and waveform distortions occurring concurrently. Also taking into account IACS’s recommendation which requires sea trials, authors carefully planned and set series of controlled experiments

during the ship voyage for determining the SMGs behaviors under voltage unbalanced and harmonic distortions occurring simultaneously.

In this paper, experimental study cases were carefully selected: full load of bow thruster supplied via power converter and small level of voltage unbalance on main switchboard bus bars (0.35%) as well as similar load with higher level of the voltage unbalances, up to 1.75%. The present research is devised as the first step toward investigation of real SMGs behaviors under unbalanced and distorted voltage conditions, which undoubtedly deserves more concern.

II. SHIPBOARD MICROGRID SYSTEM UNDER RESEARCH

A. Shipboard microgrid system description

As a typical isolated microgrid power system, the characteristics of ship microgrid includes the isolated power generations with limited capacities, different voltage and frequency levels, high short-circuit impedance of the supply power network and the extensive use of high power nonlinear/pulsed loads etc. Based on these characteristics, the system is more prone to poor power quality, such as unbalanced or distorted voltage/current waveforms, high magnitude of waveforms under transient disturbance and global frequency variations, which brings potential safety hazard to the shipboard power systems.

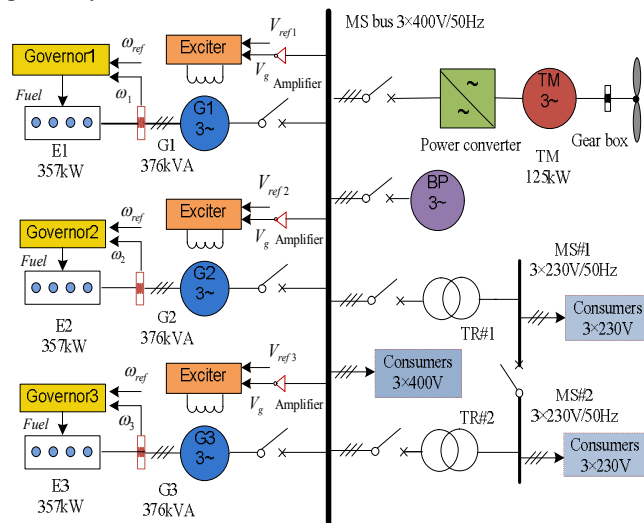

Fig.1 Simplified diagram of the SMG based ship HORIZONT II (G1, G2, G3: diesel generators; E1, E2, E3: four-stroke diesel engines; TM: bow thruster motor; TR: transformer; MS: main switchboard; BP: ballast pump)

In this research, the simplified diagram of the SMG based real ship HORIZONT II is shown in Fig. 1. The real SMG consists of three synchronous generators with the rated power of 376 kVA connected directly to the main switchboard AC bus bar. Each generator is driven by four-stroke diesel engine with the rated power of 357 kW. The load with the greatest power onboard is the bow thruster motor (125kW), which is supplied by a variable frequency power converter. The rated RMS

voltage/frequency of main switchboard bus is 400V/50 Hz. The RMS voltage of auxiliary switchboard connected with the main AC bus bar via transformers is 230V/50Hz for other power consumers.

B. Potential solutions for power quality improvement

Reactive power support control is the most common control solutions for mitigating voltage unbalances and harmonics in SMGs, and also allowed to ride through short-term dips or sags [13]. The strategies are commonly known as Q/V and P/f droop control [14]. Reactive power injection could be achieved either using existing power electronics based power sources or additional dynamic reactive power devices, such as static synchronous compensators (STATCOMs). STATCOM can combine both active and reactive power capabilities into the power converter to achieve frequency and voltage regulation and thus becoming popular in modern ship power systems [15].

On the other hand, the uninterruptible power supplies (UPS) can restrain voltage/frequency transient disturbance for low power devices in the distribution network and realize the fast recovery of voltage/current unbalances and harmonic compensations [16].

In addition, the dynamic voltage regulator (DVR) is aimed at controlling alternators voltage at main bus voltage and jointly optimizing the reactive power generated by each alternator and support the recovery of ship voltage dips [17]. The unified power quality controller (UPQC) also can be used to compensate voltage dips, frequency interruptions, and harmonic components and support reactive power [18].

III. EXPERIMENTAL STUDIES

The investigation on the real ship HORIZONT II was carried out for various configurations of the power plant and high power loads as shown in Fig.2. During the research, the behaviors of generator, bow thruster and ballast pump were monitored carefully. The ballast pumps driven by induction motors are common electrical devices to balance the ship body and ensure its stability onboard [19].

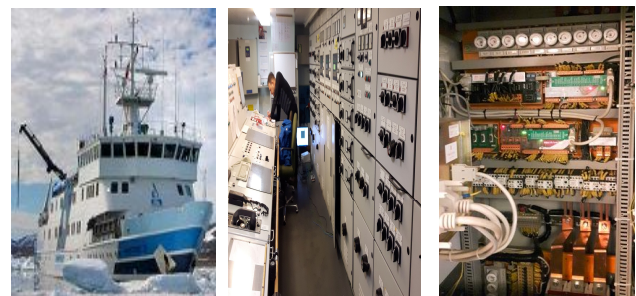

(a) Horizon II ship [20] (b) engine room (c) control board

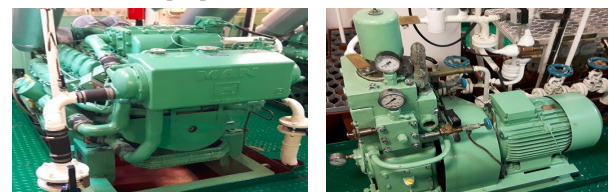

(d) diesel generator (e) pump load

Fig.2 Horizon-II research training ship test environment

The investigation on the Horizon-II research training ship was carried out for various configurations of the power plant and high power loads as shown in Fig. 2. The ship tests system with only one generator and the bow thruster motor was selected. During the research, step changes of the bow thruster motor power were introduced and ballast pump loads are started three times to generate voltage dips under different generator power levels.

The details of algorithms and mathematical formulas for respective parameters calculations are from IEC 61000-4-30 [21] and IEC 61000-4-7 [22] standards definitions and calculations based on simple Discrete Fourier Transform (DFT) with rectangular 10 cycles window were used for determining the harmonics values and subsequently THDs and harmonic currents and powers, the window duration was determined by counting the voltage zero crossing after low pass filtration. The voltage and current samples were registered by a controller (NI PXIe-8106) equipped with three DAQs (NI PXIe-6124) and anti-aliasing filters (LTC-1564). The Rogowski's coils (PEM LFR 06/6) and LEMs CV3-1500 was used for signal conditioning [23].

A. The SMGs under unbalanced and distorted AC bus voltage

Detailed behaviors of the real SMGs were monitored as follows: Generator working+ ballast pump starts (three times) + bow thruster power increasing until full loaded + ship heating system with phase A disconnected and working with phase B and C. (simulation of fuse blowing to generate the unbalanced voltage faults, the unbalances are set as moderate in real time due to the security considerations) + other ship power electrical devices (In fact, the real SMGs contains hundreds of electrical devices working at the same time, but the main harmonic sources are considered as bow thruster loads in this research.)

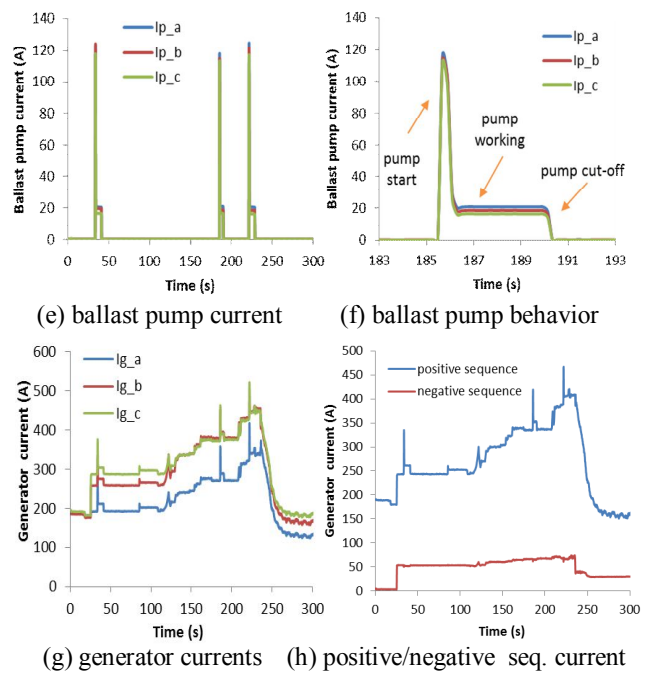
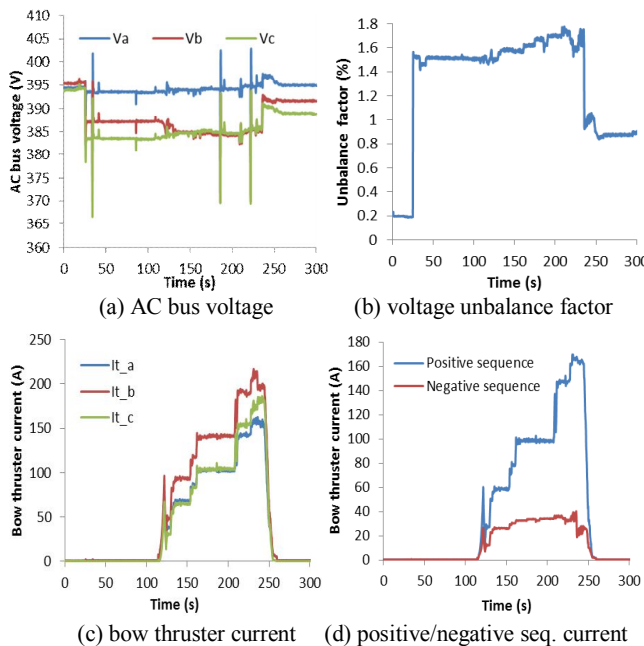

Fig.3 Experimental results of SMG under unbalanced voltage conditions

Figs. 3 (a) and (b) show the rms values of ship AC bus voltage and its unbalance factor, respectively. The unbalance factor was increasing to 1.75% with the bow thruster power increase. Next, the ballast pump started to balance ship body under sea-going but generate the AC bus voltage dips because it starts drawing a large amount of power in a very short time. As can be observed in Figs. 3(e) and (f), the ballast pump starting current can exceed 120A which contains slight unbalances, sometimes it can even reach 148 A (about 7 times of the rated working current level of ballast pump within only 0.3s. On the other hand, the generator current surges, Fig. 3(g), only occurs at the fundamental positive sequence component and does not affect the fundamental negative sequence component as shown in Fig. 3(h) because the ballast pump current contains very small negative components with quite limited capacity to disturb the negative current of the working generator.

In Figs.3 (c), (d), (g) and (h), it can be seen that the generator and bow thruster currents are severely unbalanced with the sudden transient surges for generator currents. The differences between respective line currents can reach up to 120 A (22% of generator rated current), which may trigger the overcurrent protection devices and possibly endanger ship voyage operations. In fact, the maximum rms current is higher than the respective value in the normal conditions which means unequal thermal stress for generator windings under unbalanced voltage conditions. On the other hand, the unbalanced voltage affects ship automatic voltage regulator work, which sets only highest line to line voltage to more or less rated voltage.

B. Comparative analysis of SMG under normal and unbalanced grid conditions

For the comparative analysis of SMG under normal and unbalanced grid voltage conditions, two cases were selected. First is voltage dips as transient state and second is bow thruster full load as an example of steady state.

a) Analysis of the transient voltage dips

Voltage dips are characterized by a transient decrease of rms value and usually occurred at the main switchboard bus. Voltage dips can be also divided into balanced and unbalanced conditions.

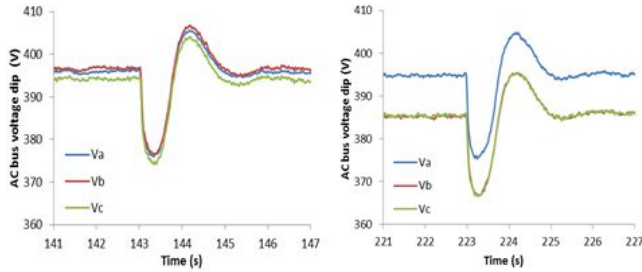

(a) normal voltage conditions (b) unbalanced voltage conditions

Fig. 4. Transient dips of AC bus voltage in two conditions

Fig. 4 shows the registered transient dips under Quasi-balanced and unbalanced AC bus voltage conditions. The voltage dip depths are about 5% of the pre-event voltage under both normal and unbalanced grid conditions. The differences between values for respective three phase voltages under normal condition remain very low up to 0.5%. The differences slightly increase for unbalanced condition to 2.5%. But the dip depth is higher due to voltage unbalances in relation to rated voltage, reaching 8.35% and the residual voltage is much lower. The detailed results of dip parameters according to standard method for Class A measurements [21] and calculations can be found in Table. I.

TABLE I. DIPS PARAMETERS DETERMINED ACCORDING TO CLASS A MEASUREMENTS (IEC 61000-4-30 [21])

Parameters		AC bus voltage [V]		Depth [%]	
		Pre-event	Residual	% of Pre-event voltage	% of rated voltage
Normal grid voltage	Va	395.72	375.98	4.99	6.00
	Vb	396.40	376.66	4.98	5.84
	Vc	394.01	374.18	5.03	6.45
Unbalanced grid voltage	Va	394.82	375.33	4.94	6.17
	Vb	385.21	366.77	4.79	8.31
	Vc	385.47	366.61	4.89	8.35

b) Analysis of the system under full load of bow thruster conditions

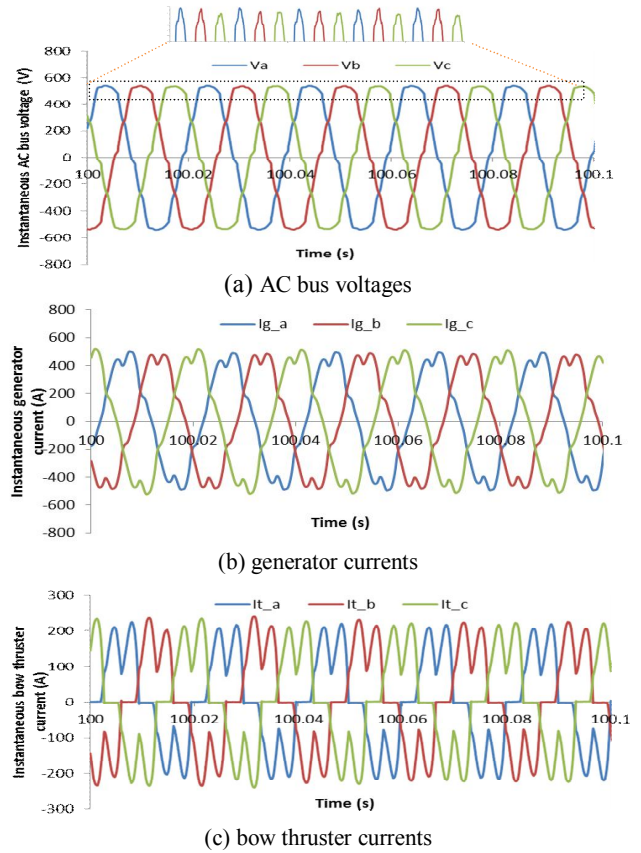
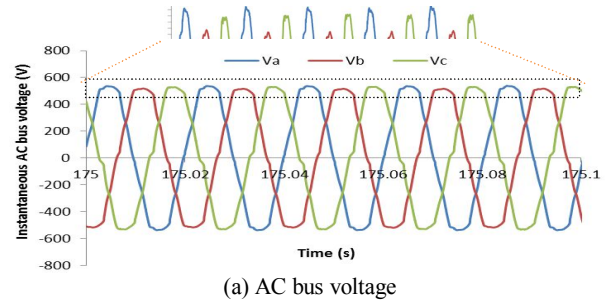

Fig. 5 Instantaneous values of AC bus voltage (a) and currents: generator (b) and bow thruster (c) under normal quasi-balanced grid conditions

Fig. 5 shows the instantaneous values of the voltage as well as generator and bow thruster currents under normal grid conditions as an example. These were registered for bow thruster full load. The voltage THD changed from 1.1% (bow thruster switched off) up to 6.7% (bow thruster full load) and remained roughly the same for all line to line voltages. Accordingly the distortions of generator and bow thruster currents were symmetrical, mainly containing 5th, 7th, 11th and 13th harmonics. Generator current THD changed from 1.5% (bow thruster switched off) up to 12.8% (bow thruster full load). Bow thruster current remained highly distorted (up to 39.6% for full load) but balanced, including the harmonics currents (differences below 2% of harmonic currents mean value (57 A) for full loaded).



(a) AC bus voltage

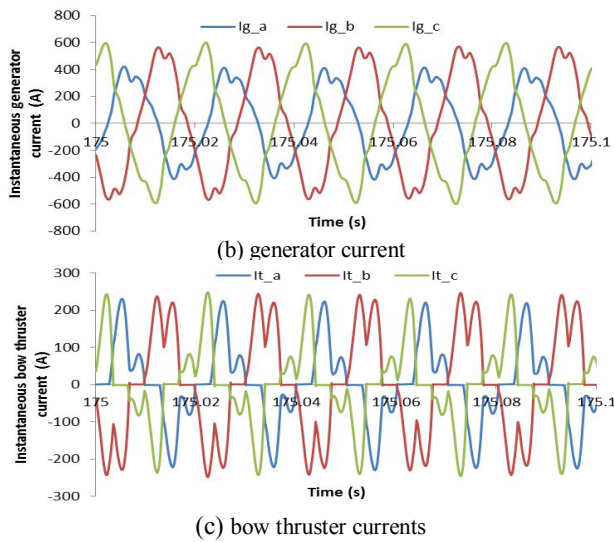

Fig. 6. Instantaneous values of AC bus voltage (a) and currents: generator (b) and bow thruster (c) under unbalanced grid conditions

In addition, Fig. 6 shows the instantaneous values of the voltage as well as generator and bow thruster currents under unbalanced grid voltage for the bow thruster full load as an example. It should be noted that for the same bow thruster load, its current THD increases for two phases and harmonic current can reach even 77 A for particular case (57 A for balanced condition). Also THDs of the line to line voltage differs even with the slight unbalances (UF=1.75%) and distortions in AC bus voltage, which means PQ problems can be more critical onboard especially under unbalanced conditions.

c) Power quality assessment for the ship microgrid under quasi-balanced and unbalanced conditions

For more comparable power quality assessment with full load of bow thruster, the main parameters, which describe the SMG behaviors under quasi-balanced and unbalanced conditions, are presented in Table II.

TABLE II. COMPARASION S OF SMG MAIN PARAMETERS FOR BALANCED AND UNBALANCED CONDITIONS

Network parameters		Shipboard microgrid	
		Quasi-balanced AC bus voltage conditions	Unbalanced AC bus voltage conditions
Main AC bus bars voltage unbalance factor		0.35%	1.75%
Main AC bus bars voltages	Va [V]	395.2	394.9
	Vb [V]	396.2	385.2
	Vc [V]	393.8	385.9
Main AC bus bars voltage distortion factors	THD_va [%]	6.43	6.04
	THD_vb [%]	6.23	6.63
	THD_vc [%]	6.43	7.33

Network parameters		Shipboard microgrid	
		Quasi-balanced AC bus voltage conditions	Unbalanced AC bus voltage conditions
Generator parameters	Active power [kW]	234.7	253.2
	Harmonic active power [kW]	-0.53	-0.62
	Nonactive power [kvar]	106.8	100.0
	Ia [A]	371.0	341.3
	Ib [A]	373.9	455.9
	Ic [A]	385.4	447.7
	THD_ia [%]	11.99	14.92
	THD_ib [%]	12.11	10.13
	THD_ic [%]	11.41	13.31
Bow thruster parameters	Active power [kW]	110.1	109.0
	Harmonic active power [kW]	-0.99	-1.26
	Nonactive power [kvar]	48.32	57.88
	Ia [A]	172.1	160.0
	Ib [A]	177.1	213.3
	Ic [A]	177.7	172.4
	THD_ia [%]	35.41	42.9
THD_ib [%]	34.88	29.81	
THD_ic [%]	35.46	47.38	
Fresh water pump parameters	Active power [kW]	6.46	6.32
	Harmonic active power [W]	6	12.4
	Nonactive power [kvar]	4.17	4.42
	Ia [A]	11.00	13.35
	Ib [A]	11.61	11.34
	Ic [A]	11.08	9.34
	THD_ia [%]	15.69	15.68
THD_ib [%]	14.97	13.76	
THD_ic [%]	15.81	24.93	

It can be seen from the Table II that unbalance lead to increase in the harmonic power flow in the system for the same active power of nonlinear load. Combining with increase in nonactive power and currents unbalance, it means additional losses in the generators, transformers and cables. Obviously, the unequal currents of generator and pump motors also mean uneven thermal stress of the machines windings, which can lead to increased speed of overall thermal ageing. It should be noted that the harmonic power flows mainly from the bow thruster to the generator and also go through the fresh water

pump and other devices, which also means that the bow thruster is the main harmonic source in this system.

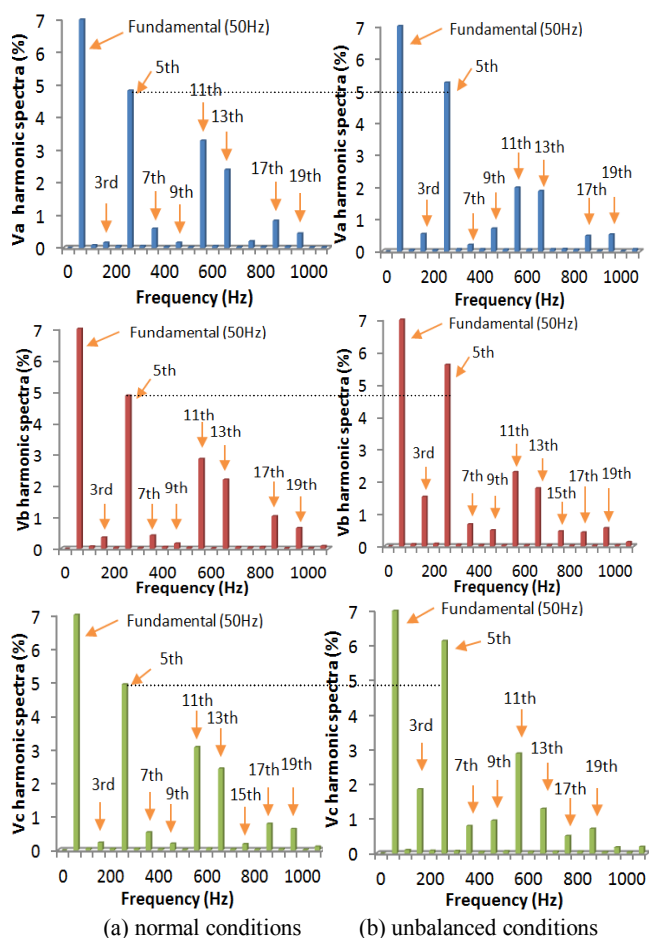

Fig. 7 Harmonic spectra of AC bus voltages up to 25th harmonic under full load of bow thruster

One of the effects of voltage unbalance is relatively significant difference between voltage THDs, as can be seen in the Table III. However, it does not mean that all of harmonic values changes proportionally. As can be seen in Fig. 7, the spectra of voltages changes, e.g. fifth harmonic content increases, it can be even beyond 6% of the fundamental component, and significant value of third harmonics appears under unbalanced condition, which also means the power quality assessment under unbalanced AC bus voltage conditions is more challenging for the SMGs.

IV. CONCLUSIONS

This paper provides valuable experimental investigations on the power quality assessment onboard. It highlights the particular effects of voltage unbalance and distortions in the real SMG. The permissible voltage unbalances should be tied with the level of voltage waveform distortion, which means that flexible threshold of the unbalance factor has to be adopted in the future maritime standards. Furthermore, the transient voltage dips caused by sudden-load of ballast pump can lead to

generator current surges, which may also be treated as hazard to the ship power system.

In our conclusions, the differences between critical grid parameters under balanced and unbalanced conditions are quite huge in the real ship power system. It particularly concerns increase of voltage THD for some line to line voltages, which can adversely impact on operation of sensitive one phase receivers, which must be taken into account by the system integrator, when calculating the level of harmonic distortion experienced, the effect augments problems resulting from current distortions, like increase in harmonic active power flow in the system. It clearly necessitates the amendment current maritime standards and including unbalance factor into them.

ACKNOWLEDGMENT

This work was supported partly by the National Science Centre, Poland under Grant DEC-2012/07/E/ST8/01688 and China Scholarship Council Grant (CSC.201508130077). More information related to the maritime microgrid systems research can be found in www.maritime.et.aau.dk.

REFERENCES

- [1] Skjong, E., Volden, R., Rødskar, E., Molinas, M., Johansen, T.A. and Cunningham, J. Past, Present, and Future Challenges of the Marine Vessel's Electrical Power System. *IEEE Transactions on Transportation Electrification*, vol.2. no.4, pp.522-537. 2016.
- [2] Shariatzadeh, F., Kumar, N. and Srivastava, A.K., Optimal Control Algorithms for Reconfiguration of Shipboard Microgrid Distribution System Using Intelligent Techniques. *IEEE Transactions on Industry Applications*, vol.53.no.1, pp.474-482. 2017.
- [3] *IEEE Standard 45-2002*, IEEE Recommended Practice for Electrical Installations on Shipboard.
- [4] MAIB (2011), Marine Accident Investigation Branch, Report on the investigation of the catastrophic failure of a capacitor in the aft harmonic filter room on board RMS Queen Mary 2 while approaching Barcelona on 23 September 2010. http://www.maib.gov.uk/publications/investigation_reports/2011/qm2.cfm (last access 20.11.2017).
- [5] Gnacinski, P., Windings Temperature and Loss of Life of an Induction Machine Under Voltage Unbalance Combined With Over or Under voltages, *IEEE Transactions on Energy Conversion*, vol. 23, no. 2, pp. 363-371. 2008.
- [6] Su, Chun-Lien, Ching-Jin Chen, and Ching-Cheng Lee. "Fast Evaluation Methods for Voltage Sags in Ship Electrical Power Systems." *IEEE Transactions on Industry Applications*, vol.49 no.1. pp: 233-241. 2013.
- [7] Chin, Hai-Ming, Chun-Lien Su, and Chi-Hsiang Liao. "Estimating Power Pump Loads and Sizing Generators for Ship Electrical Load Analysis." *IEEE Transactions on Industry Applications*, vol.52, no. 6 pp: 4619-4627. 2016
- [8] DNV DL. Casualty information for unbalanced engine forces and vibration on board ships, *Det Norske Veritas*, DTP 245.
- [9] Su, Chun-Lien, Kun-Liang Lin, and Ching-Jin Chen. "Power flow and generator-converter schemes studies in ship MVDC distribution systems." *IEEE Transactions on Industry Applications*, vol.52, no. 1 pp: 50-59. 2016.
- [10] Gnacinski, P, Tarasiuk, T, Energy-efficient operation of induction motors and power quality standards, *Electric Power Systems Research*, vol. 135, pp. 10-17, June 2016.
- [11] Bruzese, C., T. Mazzuca, and M. Torre. "On-line monitoring of mechanical unbalance/misalignment troubles in ship alternators by direct measurement of split-phase currents." *In Electric Ship Technologies Symposium (ESTS), IEEE*. pp. 379-386., 2013.
- [12] *International Association of Classification Societies*, Requirements Concerning Electrical and Electronic Installations, *IACS Reg.* 2016.

- [13] Wenzhao Liu, X. Guo, G. Sulligoi et.al "Enhanced Power Quality and Minimized Peak Current Control in An Inverter based Microgrid under Unbalanced Grid Faults" *Proceedings of 8th Energy Conversion Congress & Exposition. IEEE*, Sep. 2016.
- [14] Josep M. Guerrero, Juan. C. Vasquez, J. Matas et.al "Hierarchical control of droop-controlled AC and DC microgrids-A general approach toward standardization," *IEEE Trans.Ind. Electron.* vol. 58, no. 1, pp. 158-172, Jan. 2011
- [15] Mitra, Pinaki, Ganesh Kumar Venayagamoorthy. "An adaptive control strategy for DSTATCOM applications in an electric ship power system. ", *IEEE Transactions on Power Electronics* vol 25.no.1 pp. 95-104.2010.
- [16] Sulligoi, Giorgio, Andrea Vicenzutti, Vittorio Arcidiacono, and Yuri Khersonsky. "Voltage stability in large marine-integrated electrical and electronic power systems." *IEEE Transactions on Industry Applications*, vol. 52, no. 4 pp: 3584-3594. 2016
- [17] Arcidiacono, Vittorio, Roberto Menis, and Giorgio Sulligoi. "Improving power quality in all electric ships using a voltage and VAR integrated regulator." *In Electric Ship Technologies Symposium, ESTS'07. IEEE*, pp. 322-327. May, 2007.
- [18] Han, B, B. Bae, H. Kim, and S. Baek. "Combined operation of unified power-quality conditioner with distributed generation." *IEEE Transactions on Power Delivery* vol.21, no. 1 pp.330-338. 2006
- [19] T. Tarasiuk, J. Mindykowski, An extended interpretation of THD concept in the wake of ship electric power systems research, *Measurement*, vol. 45, no 2, 2012, pp. 207-212.
- [20] <http://www.am.gdynia.pl/sites/default/files/zalaczniki/horyzont2.jpg>, T. Degorski, (last access 20.11.2017).
- [21] IEC Standard 61000-4-30: 'Testing and Measurement Techniques – Power Quality Measurement Methods', 2015.
- [22] International Electrotechnical Commission. "IEC 61000-4-7." *Electromagnetic Compatibility (EMC)-Part 4*, 2004.
- [23] T. Tarasiuk, M. Gorniak. "Load Sharing in Ship Microgrids under Nonsinusoidal Conditions–Case Study." *IEEE Transactions on Energy Conversion* . vol .32,no.2, pp.810-819. June, 2017.