

# Extreme Fast Charging Station Architecture for Electric Vehicles with Partial Power Processing

Vishnu Mahadeva Iyer<sup>†</sup>, Srinivas Gulur<sup>†</sup>, Ghanshyamsinh Gohil<sup>‡</sup> and Subhashish Bhattacharya<sup>†</sup>

<sup>†</sup>North Carolina State University, Raleigh, USA. Email: [vmahade@ncsu.edu](mailto:vmahade@ncsu.edu), [sgulur@ncsu.edu](mailto:sgulur@ncsu.edu), [sbhatta4@ncsu.edu](mailto:sbhatta4@ncsu.edu)

<sup>‡</sup>The University of Texas at Dallas, Texas, USA. Email: [Ghanshyam.Gohil@utdallas.edu](mailto:Ghanshyam.Gohil@utdallas.edu)

**Abstract**—This paper introduces a power delivery architecture for an Extreme Fast Charging (XFC) station that is meant to simultaneously charge multiple electric vehicles (EVs) with a 300-mile range battery pack in about 15 minutes. The proposed approach can considerably improve overall system efficiency as it eliminates redundant power conversion by making use of partial power rated dc-dc converters to charge the individual EVs as opposed to a traditional fast charging station structure based on full rated dedicated charging converters. Partial power processing enables independent charging control over each EV, while processing only a fraction of the total battery charging power. Energy storage (ES) and renewable energy systems such as photovoltaic (PV) arrays can be easily incorporated in the versatile XFC station architecture to minimize the grid impacts due to multi-mega watt charging. A control strategy is discussed for the proposed XFC station. Experimental results from a scaled down laboratory prototype are provided to validate the functionality, feasibility and cost-effectiveness of the proposed XFC station power architecture.

**Index Terms**—dc fast charger, dc-dc power converters, extreme fast charger, energy storage, fast charging station, partial power processing.

## I. INTRODUCTION

Superior performance, lower operating cost, reduced greenhouse gas emissions, improvement in the battery technology and driving range, along with the reduction in the vehicle cost have led to significant increase in the adoption rate of Battery Electric Vehicles (BEVs) and Plug-in Hybrid Electric Vehicles (PHEVs). Cumulative sales of highway licit BEVs and PHEVs surpassed a major milestone of 2 million units, of which 38% were sold in 2016 [1]. Analysis indicates that the lack of charging infrastructure and prolonged charging time can lead to driving range anxiety [2], [3]. One of the ways to address the range anxiety issue is to increase the battery capacity. However, it leads to an increase in the price and weight of the vehicle. Therefore, the preferred option is to improve the charging infrastructure and reduce charging time.

Early adopters of EVs primarily use it for daily commute and short trips. Considering moderate use of the vehicle, ac level 1 charging (< 2 kW) or ac level 2 charging (> 2 kW and < 10 kW) is most frequently used in a residential or workplace setting. Level 2 ac charging is also typically used at both private and public facilities. For longer commutes, dc fast charging (> 20 kW and < 120 kW) stations are being deployed [4]. While level 1 and level 2 charging are sufficient

in most cases for daily commute and short trips, EV manufacturers believe that Extreme Fast Charging (XFC) (> 350 kW) is required for long range EVs [5], [6]. XFC can potentially reduce the battery charging time to make it comparable to the typical refueling time of the conventional Internal Combustion (IC) engine vehicles. Porsche has demonstrated an all-electric 300-mile range concept vehicle, Mission E, which can support 350 kW XFC and operates at a dc voltage of 800 V. Porsche plans to launch such a vehicle by 2020 [7]. XFC system for a 300-mile range vehicle can cost up to \$100,000 per system. In addition, it requires special equipment, installation procedures, permits and costly maintenance warranties [8]. Therefore, this will be typically owned by the commercial customers or EV manufactures. Several XFC systems can be arranged together to form an XFC station. Since an XFC station constitutes multiple XFC systems, it presents an opportunity for the reduction of capital investment and operating costs to make it economically viable.

In addition to the energy charges, commercial customers are often subject to demand charges. Demand charges are typically determined based on the peak value of electricity demand with a duration higher than 15 minutes. Demand charges are imposed to discourage the user from drawing higher peak power so that the stress on distribution infrastructure such as transformers and voltage regulators in distribution feeders, in terms of thermal cycling can be avoided. Since XFC stations can draw very high value of peak powers for very short durations, high demand charges can lead to increase in operating cost and reduction in profitability of the same [9]. In order to reduce stress on the grid infrastructure and to avoid excess demand charges, centralized energy storage and on-site energy generation need to be incorporated. The inclusion of on-site generation and storage facilitates smoothening of the power drawn from the grid. XFC stations are likely to see potential cost savings with the incorporation of on-site generation and energy storage integration [10]. If Time of Use (TOU) rates are used, energy can be stored during off-peak hours when the energy charges are minimum and utilized to charge EVs during peak hours when the energy charges are high. Moreover, the on-site generation and storage enables XFC stations to participate in a demand response program. XFC stations with energy storage also presents the opportunity for arbitrage, provided a Front-End Converter (FEC) with bi-directional power flow capability is employed.

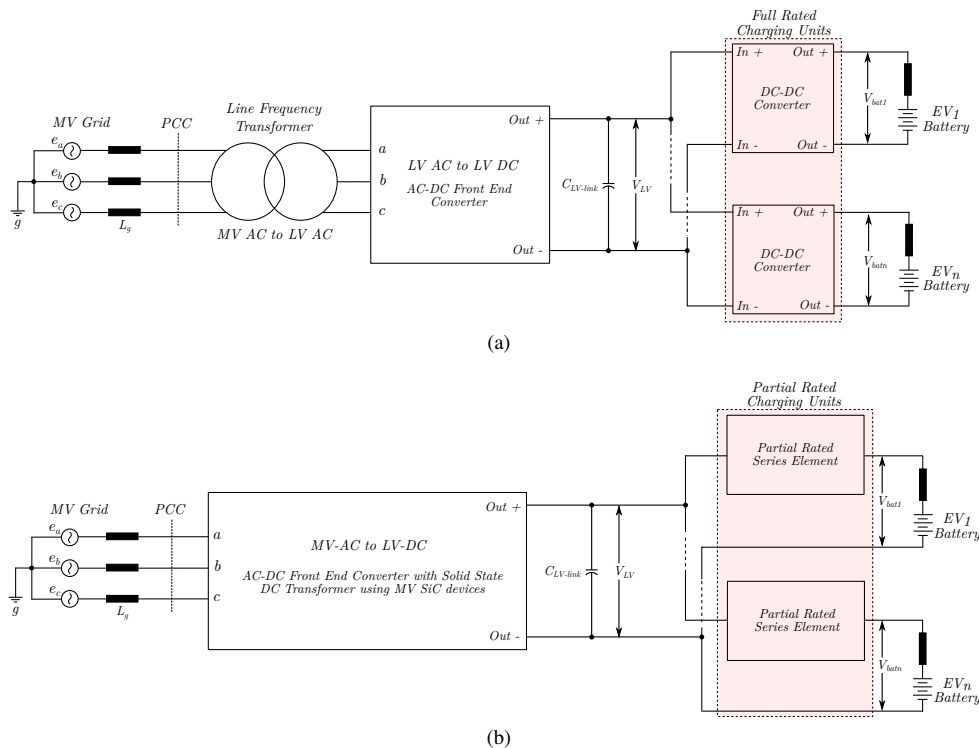

Fig. 1: XFC station power delivery architecture (a) Conventional scheme with line frequency transformer and full rated charging converters (b) Proposed scheme with MV grid interface and partial rated charging converters. In both schemes, on-site generation and energy storage systems can be easily incorporated to the LV DC link (not illustrated for clarity purposes).

The common approach of realizing an XFC station is to have a centralized FEC unit that interfaces with the Medium Voltage (MV) grid using a line frequency transformer and separate dc-dc converter units for each of the XFC systems as shown in Fig. 1a [10]. Thanks to the grid power smoothing due to the addition of energy storage and on-site generation, power rating of the FEC unit and isolation transformer can be reduced, which leads to a reduction in capital investment. However, each charging port requires a full rated (350 kW) dc-dc converter which can add to the capital and operational costs. This work proposes a new system level solution that aims to improve the energy efficiency of XFC stations. A different power delivery architecture is proposed that can considerably reduce the installation and operational costs in a multi-port XFC station and simultaneously improve the overall system efficiency. The novelty of the architecture lies in the use of partial rated dc-dc power converters for each charging port as against the full power dc-dc converter based charging solution reported in literature. This improved power delivery scheme is shown in Fig. 1b. The partial rated converter acts as a series connected voltage buffer that is rated only to handle a fraction of the power required for battery charging.

The paper is organized as follows. Section II lists the key subsystems in the proposed XFC power delivery scheme. Section III introduces the partial power processing charging unit and describes its features. Section IV outlines the different operating modes of the XFC station. Section V discusses the

overall control strategy and Section VI provides experimental results from a scaled down laboratory prototype.

## II. XFC STATION POWER DELIVERY SCHEME - SUBSYSTEMS

There are three main subsystems in any XFC station power delivery architecture.

### A. AC-DC Front End Converter and Isolation Transformer

Due to the large power requirement, XFC station will have to be connected to the Medium-Voltage (MV) grid. This is traditionally achieved using a line frequency transformer (refer Fig. 1a). The weight, size, volume and large footprint of the line frequency transformer are big concerns, especially in urban areas where cost of land is high.

A MV grid interfaced solution that eliminates the line frequency transformer is preferred. Some of the popular grid interfacing solutions are multilevel, cascaded H Bridge (CHB), modular multilevel converters (MMCs), etc. Recent advancements in MV Silicon Carbide (SiC) devices enable the use of simple MV grid interfaced power converters [11]. A two level MV Voltage Source Converter (VSC) cascaded with a Medium Frequency (MF) Dual Active Bridge (DAB) converter that acts as a solid-state transformer is proposed. This reduces circuit complexity and simplifies the control strategy as compared to traditional Silicon (Si) based XFC solutions reported in literature [6]. The MV VSC converts three-phase MV ac to

MV dc and MF DAB converter transforms MV dc to the required low voltage (LV) dc level.

### B. On-site Generation and Central Battery Energy Storage System (BESS)

The centralized BESS and on-site PV generation are optional features that can have a huge impact on the system operating costs. They are needed for power smoothing to reduce the stress on the grid infrastructure. Such features can equally benefit both the conventional and proposed power delivery schemes and can be easily integrated to the LV dc link by using an active dc-dc converter.

### C. Charging Unit

The charging unit is responsible for power distribution to individual EVs. In a conventional power delivery scheme, a dedicated full rated converter is allotted for each charging port where as a partial rated series element is used for achieving independent charging operation in the proposed scheme.

## III. PARTIAL POWER PROCESSING CHARGING UNIT

This section describes the unique features that the partial rated converter should possess so that it can be used for a battery charging application. Then a suitable topology is identified and system level benefits in using the proposed scheme with partial power processing is summarized.

### A. Features of Partial Rated Charging Unit

The key operational features of partial rated charging unit are listed below.

- 1) Needs to act as a voltage buffer.
- 2) Should not create a direct shorting of two or more EV batteries at any instant.
- 3) Avoid any circulating current between two or more EV batteries.
- 4) Should not consume any active power in an ideal scenario.
- 5) Facilitate independent control of individual EV battery currents.
- 6) Ripple free battery current.

Based on these requirements, two different series connected realizations are possible for the partial rated charger as shown in Fig. 2. The charger input port voltage,  $V_{in}$  is determined

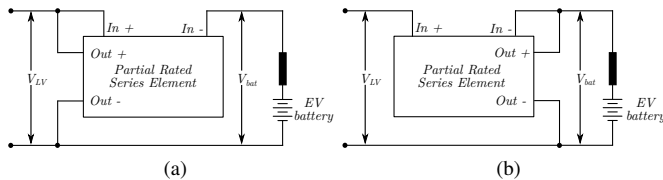

Fig. 2: Partial power rated charger connection schematics (a) Scheme 1 (b) Scheme 2.

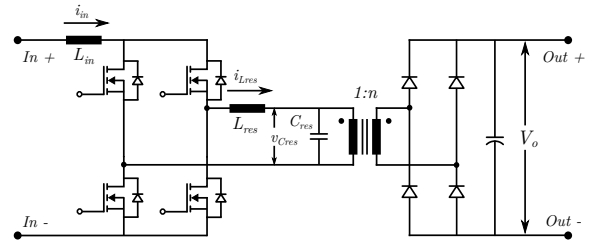

Fig. 3: Partial power rated charger based on a current fed resonant full bridge boost converter.

by the difference voltage between the LV dc link and any EV battery.

$$V_{in} = V_{LV} - V_{bat} \quad (1)$$

Since the series converter should not consume any power, its output should be fed back to either the LV dc link as in Scheme 1 or to the EV battery as in Scheme 2 shown in Fig. 2. This will generally require an isolated converter topology to not cause a short between its input and output ports.

### B. Example Realization

Several practical realizations are possible for the partial rated charging converter. As an example, a current-fed isolated full-bridge dc-dc converter topology shown in Fig. 3 is selected as the charging unit. Scheme 1, wherein the converter output is fed back to the LV dc link, is used for interfacing the converter with the system. There are several advantages in using the current-fed isolated full-bridge topology.

- 1) In this realization, the battery charging current is same as the input inductor current and hence, there is a natural smoothing of the battery current.

$$i_{bat} = i_{in} \quad (2)$$

- 2) Suited for higher power applications and can easily be scaled up.
- 3) Ideally suited for applications with a low input voltage and high output voltage as in this case.
- 4) Low losses. Resonant operation ensures either Zero Voltage Switching (ZVS) or Zero Current Switching (ZCS) based on the design and control strategy. Output rectifier diodes undergo ZCS.

As discussed, the converter has to process only a fraction of the power needed for battery charging.

$$P_{bat} = V_{bat} I_{bat} \quad (3)$$

$$P_{charger} = (V_{LV} - V_{bat}) I_{bat} \quad (4)$$

The power handled by the partial rated charger can be reduced by judiciously choosing  $V_{LV}$ . A representative per unitized power plot over one XFC cycle showing the benefits of the partial rated charger is given in Fig. 4. A constant current (CC) charging operation is assumed while plotting Fig. 4. The LV dc link voltage,  $V_{LV}$  is held constant. For a specific value of  $V_{LV}$ , the maximum power processed by the charger is only about one third of the maximum power demanded by the battery.

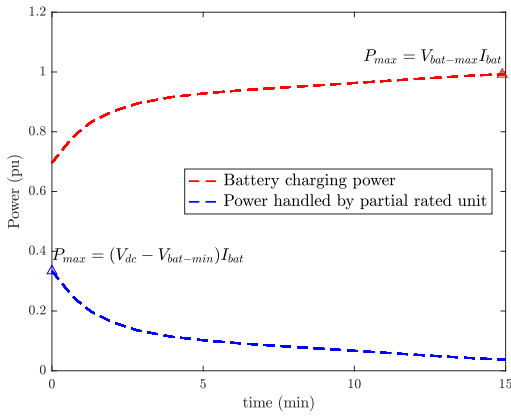

Fig. 4: Per unitized power plots over one XFC charging cycle.

This can translate into huge power and energy savings for a multi-MW multi-port XFC station. The current-fed isolated full-bridge dc-dc converter design considerations are given in [12], [13]. A laboratory prototype of the current fed full-bridge converter is realized as shown in Fig. 5.

### C. System Level Benefits

To showcase the system level benefits with the proposed approach, an example multi-mega watt XFC station with six charging ports, each rated at 350 kW, is considered. It is assumed that the station is capable of simultaneously charging up to 6 EVs. Currently, there is a trend to move towards the 800 V system in passenger vehicles to facilitate XFC [7], [14] and hence, such a system is considered for this analysis. Typical ratings of a 6 port XFC station are given in Table I.

TABLE I: Typical XFC station ratings with 6 charging ports.

| Parameter        | Value             |
|------------------|-------------------|
| $e_{abc}$        | 4.16 kVrms, 60 Hz |
| $V_{LV}$         | 850 – 870 V       |
| $V_{EV-battery}$ | 650 – 830 V       |
| $P_{max}$        | 2.1 MW            |



Fig. 5: Partial power rated charger realized in laboratory - Scaled down prototype.

Based on the per unitized analytical plots in Fig. 4, the power and energy savings over one full charging cycle with partial rated charging units can be estimated as compared to the conventional solution with full rated charging units. One full charging cycle refers to the worst-case operation where 6 EVs are simultaneously getting charged for a period of 15 minutes.

The total power losses,  $P_{loss-total}(t)$  in the charging unit can be calculated based on the power losses,  $P_{loss-charger}(t)$  in each charger.

$$P_{loss-charger}(t) = (1 - \eta_{charger})P_{charger}(t) \quad (5)$$

$$P_{loss-total}(t) = 6P_{loss-charger}(t) \quad (6)$$

This in turn can be used to compute the extra energy needed to meet the losses in the charger over one full charging cycle.

$$E_{loss} = \int_0^{(15/60)} P_{loss-total}(t) dt \quad (7)$$

TABLE II: System level comparison.

| Parameter               | Conventional Scheme | Proposed Scheme |
|-------------------------|---------------------|-----------------|
| $P_{charger-max}$       | 350 kW              | 117 kW          |
| $P_{charging-unit-max}$ | 2.1 MW              | 702 kW          |
| $\eta_{charger}$        | 95 %                | 95 %            |
| $E_{loss}$              | 24.25 kWh           | 2.62 kWh        |

$P_{charger-max}$  - Power rating of each charger,  $P_{charging-unit-max}$  - Power rating of entire charging unit with 6 chargers,  $\eta_{charger}$  - Efficiency of each charger and  $E_{loss}$  - Energy requirement to meet losses in the charging unit over one full charging cycle.

Table II summarizes the key system level benefits with the proposed approach. The same charger efficiency was assumed (95 %) for the conventional and proposed schemes so as to make a fair comparison. Since power processed by the partial rated charger is much lower than that of the conventional full rated charger, the absolute value of charger losses is significantly less even with the same charger efficiency. As a result, the extra energy that needs to be expended to meet the charger losses can be reduced from 24.25 kWh to 2.62 kWh (almost a 10-fold reduction) in just one full charging cycle. The advantages with the proposed scheme are given below-

- 1) Lower rated charging units  $\Rightarrow$  less capital cost.
- 2) Reduced energy requirements  $\Rightarrow$  less operational cost.

## IV. XFC STATION OPERATING MODES

The different operating modes of the XFC station are outlined in this section. An XFC station with a central BESS for smoothening the grid power is considered here.

### A. EV Charging Mode

There are two possible scenarios in this mode. In the first scenario, active power is transferred from MV ac grid to EV batteries. A part of the charging power could also be supplied by the central BESS to EV batteries. Here, central BESS aids the grid during heavy loading conditions or during peak hours.

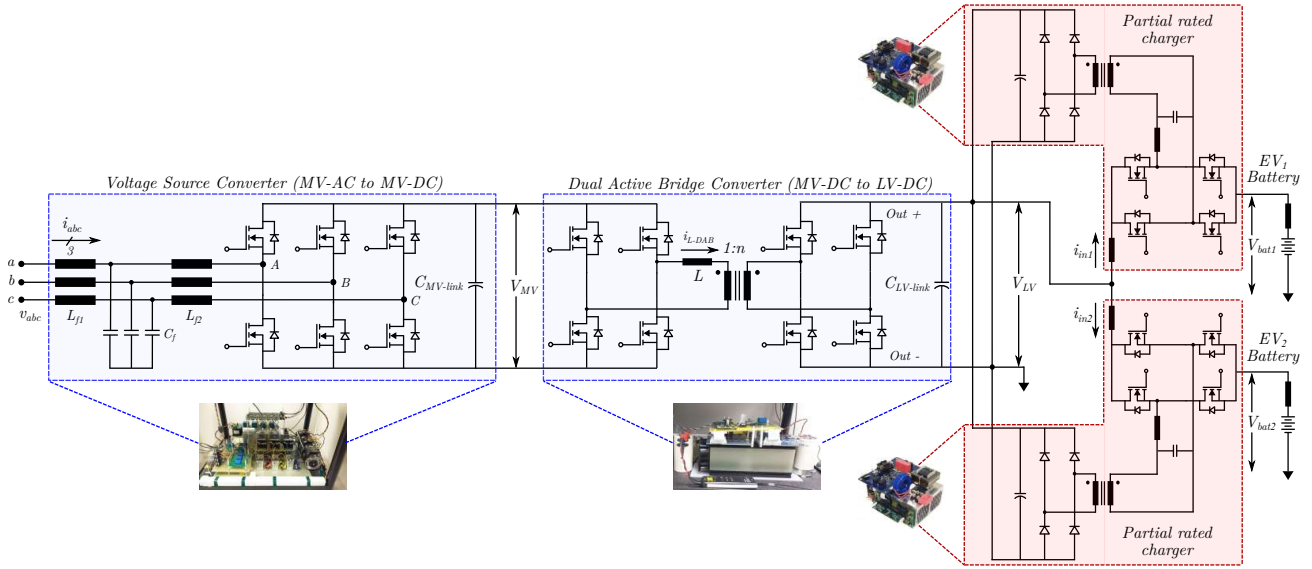

Fig. 6: Laboratory testbed for the XFC station with two charging ports. The converters developed are downscaled versions in terms of voltage and power rating.

In the second scenario, active power is transferred from the MV ac grid to the central BESS. A part of the active power could also go to the EV batteries. Here, central BESS will get charged during light loading conditions or during off-peak hours.

### B. BESS to Grid Mode

Grid operators are showing an increasing interest in making use of inverter coupled generation/storage to help mitigate frequency contingency events [15]. In this mode, central BESS supplies active power at a rapid rate to the grid thereby offering grid frequency support. This mode could be activated during contingency events.

### C. Reactive Power Support Mode

In this mode, the grid connected FEC converter will be utilized for offering Volt Ampere Reactive (VAR) support to

the grid. The FEC can exchange both leading and lagging VARs for grid support.

## V. GLOBAL CONTROL STRATEGY

A downscaled laboratory testbed as in Fig 6 with two charging ports was developed to validate the functionality and control algorithms. The overall control block diagram for the proposed topology is given in Fig. 7.

### A. Voltage Source Converter

The Voltage Source Converter (VSC) regulates the MV dc link voltage. The PCC voltages,  $v_{abc}$  are used in a conventional SRF-PLL for synchronization with the three-phase grid and the grid currents,  $i_{abc}$  are used for implementing current control in a rotating  $dq$  reference frame. The VSC can be controlled appropriately to exchange active or reactive power with the grid.

### B. Dual Active Bridge Converter

The main function of the solid-state dc transformer (DAB converter) is to regulate the LV dc link voltage. The phase-shift between the bridge voltages, duty ratio of the bridge voltages or frequency of operation can be controlled to regulate the LV dc link voltage. In addition, a dead beat predictive current control is needed in a DAB to minimize any transient dc currents in the high frequency ac link.

### C. Partial Rated Charger

The partial power dc-dc converters are used to charge the EV batteries. The input current of the partial rated series element is controlled to inject a desired current into the EV battery. For the full bridge resonant boost converter, a variable frequency control as in [12] must be implemented to ensure ZCS operation of all the active switches.

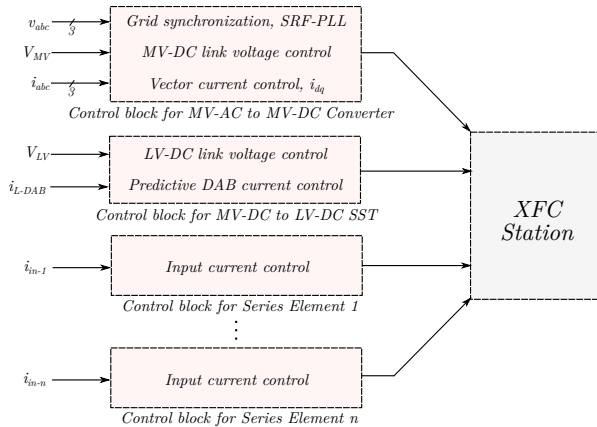

Fig. 7: Global control strategy for the XFC station.

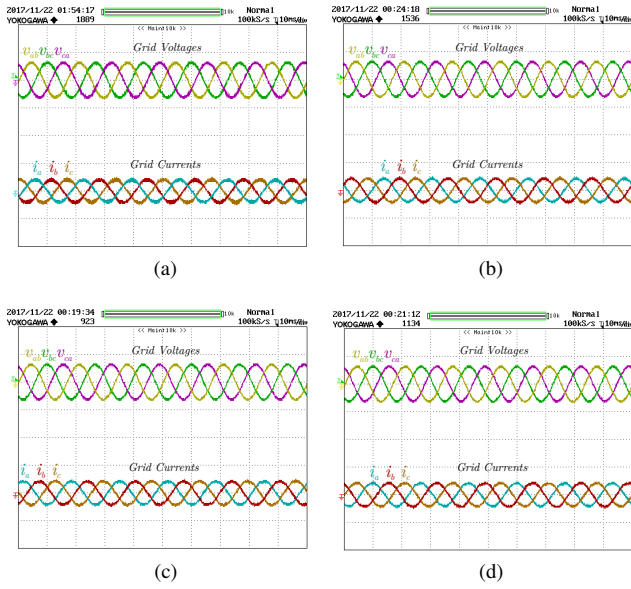

Fig. 8: Operating modes of the XFC station - FEC line voltages (200 V/div) and line currents (20 A/div) (a) Charging Mode (b) BESS to Grid Mode (c) Reactive power support - leading VARs (d) Reactive power support - lagging VARs.

## VI. RESULTS AND DISCUSSION

### A. XFC Station Operating Modes

Different operating modes of the XFC station are emulated using the laboratory testbed. Fig. 8a shows the battery charging mode where active power is drawn from the grid. Fig. 8b shows the BESS to Grid mode. To perform this test, a dc power source was connected at the LV dc link (instead of a central BESS) from which active power is supplied to the grid. Fig. 8c and Fig. 8d show reactive power support feature wherein the VSC exchanges leading and lagging VARs with the grid respectively.

The circuit parameters of the VSC and DAB converter that are used in the hardware testbed are given in Table III and Table IV respectively. Even though, an LCL type grid filter is shown in Fig. 6, a simple L filter was used while testing the different modes of operation.

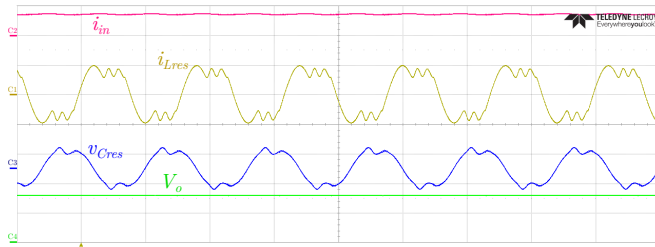

Fig. 9: Standalone operation of partial power rated charger. Key: C1 -  $i_{Lres}$  (10 A/div), C2 -  $i_{in}$  (10 A/div), C3 -  $v_{Cres}$  (200 V/div), C4 -  $V_o$  (200 V/div).

TABLE III: Voltage Source Converter Parameters

| Parameter                              | Value       |
|--|-------------|
| AC filter inductance, $L_{f1}, L_{f2}$ | 1 mH        |
| AC filter capacitance, $C_f$           | —           |
| DC link capacitance, $C_{MV-link}$     | 650 $\mu$ F |
| Switching frequency, $f_{sw-VSC}$      | 20 kHz      |

TABLE IV: DAB Converter Parameters

| Parameter                          | Value       |
|------------------------------------|-------------|
| DAB inductance, $L$                | 64 $\mu$ H  |
| Transformer turns ratio, 1 : $n$   | 1 : 1       |
| DC link capacitance, $C_{LV-link}$ | 450 $\mu$ F |
| Switching frequency, $f_{sw-DAB}$  | 50 kHz      |

### B. Partial Rated Charging Unit

Experimental test results to validate the operation of the partial rated charging unit are presented. The specifications of the partial rated charger are given in Table V.

TABLE V: Full Bridge Resonant Boost Converter Parameters

| Parameter                         | Value        |
|-----------------------------------|--------------|
| Output Voltage, $V_o = V_{LV}$    | 400 V        |
| Battery Voltage, $V_{bat}$        | 300 – 350 V  |
| Input Voltage, $V_{in}$           | 50 – 100 V   |
| Input Current, $i_{in} = i_{bat}$ | 7.8 A        |
| Boost inductance, $L_{in}$        | 260 $\mu$ H  |
| Resonant inductance, $L_{res}$    | 8 $\mu$ H    |
| Resonant capacitance, $C_{res}$   | 68 nF        |
| Switching frequency, $f_{sw}$     | 50 – 150 kHz |

1) *Standalone Tests*: Experimental waveforms from the standalone mode of operation of the partial rated charger are presented in Fig. 9. The input current,  $i_{in}$  was regulated at 7.8 A by varying the switching frequency. The input voltage,  $V_{in}$  was maintained at 50 V while the output voltage was 325 V. The resonant inductor current and resonant capacitor voltage waveforms are also shown.

2) *System level Tests*: Two partial power rated chargers were used to simultaneously charge two batteries (battery like behavior was emulated) and the test results are given in Fig. 10. It is to be noted that the battery voltages were chosen to be

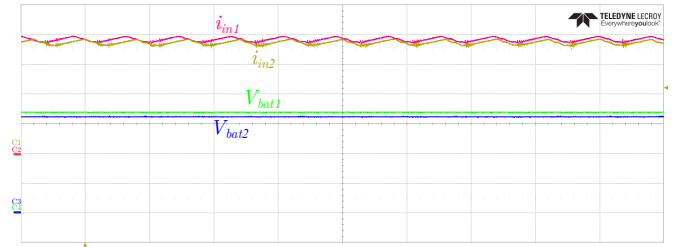

Fig. 10: Two partial power chargers simultaneously charging two individual batteries. Key: C1 -  $i_{in1}$  (2 A/div), C2 -  $i_{in2}$  (2 A/div), C3 -  $V_{bat1}$  (100 V/div), C4 -  $V_{bat2}$  (100 V/div).

slightly different (322 V and 337 V) to showcase autonomous control of battery currents. Both chargers independently regulated the respective battery currents to 7.8 A. Thus, it can be concluded that a charger that is rated to handle only a fraction of the battery power is sufficient enough to enable a smooth battery charging operation.

## VII. CONCLUSION

A multi-mega watt power delivery architecture for an XFC station that makes use of partial power processing is proposed. As opposed to a conventional system, partial rated dc-dc converters are used to charge the individual EVs. System level benefits of using the proposed power delivery scheme include lower capital investments, lower operational costs and improved power and energy efficiency. The features and requirements of using such a partial rated converter for a battery charging application are discussed and a suitable converter topology is identified for the charger. Global control strategy for the XFC station is discussed. Experimental results from a downscaled laboratory testbed validate the feasibility and functionality of the proposed system.

## REFERENCES

- [1] "Global EV outlook 2017," International Energy Agency, [Online]. Available: <https://www.iea.org/publications/freepublications/publication/GlobalEVO Outlook2017.pdf>, 2017 (Accessed 27th November 2017).
- [2] L. Dickerman and J. Harrison, "A new car, a new grid," *IEEE Power and Energy Magazine*, vol. 8, no. 2, pp. 55–61, March 2010.
- [3] A. Meintz *et al.*, "Enabling fast charging - Vehicle considerations," *Journal of Power Sources - Elsevier*, vol. 367, pp. 216–227, Nov 2017.
- [4] D. Karner, T. Garetson, and J. Francfort, "EV charging infrastructure roadmap," Idaho National Laboratory, [Online]. Available: <https://avt.inl.gov/sites/default/files/pdf/evse/EVChargingInfrastructureRoadmapPlanning.pdf>, 2016 (Accessed 27th November 2017).
- [5] D. Aggeler, F. Canales, H. Zelaya, D. L. Parra, A. Coccia, N. Butcher, and O. Apeldoorn, "Ultra-fast dc-charge infrastructures for EV-mobility and future smart grids," in *2010 IEEE PES Innovative Smart Grid Technologies Conference Europe (ISGT Europe)*, Oct 2010, pp. 1–8.
- [6] M. Vasiladiotis and A. Rufer, "A modular multiport power electronic transformer with integrated split battery energy storage for versatile ultrafast ev charging stations," *IEEE Transactions on Industrial Electronics*, vol. 62, no. 5, pp. 3213–3222, May 2015.
- [7] "Tribute to tomorrow. Porsche Concept Study Mission E." Porsche, [Online]. Available: <https://www.porsche.com/microsite/mission-e/international.aspx> (Accessed 27th November 2017).
- [8] "Evaluating electric vehicle charging impacts and customer charging behaviors - experiences from six smart grid investment grant projects," Smart Grid Investment Grant Program, US Department of Energy, Dec 2017.
- [9] A. Burnham *et al.*, "Enabling fast charging - Infrastructure and economic considerations," *Journal of Power Sources - Elsevier*, vol. 367, pp. 237–249, Nov 2017.
- [10] "Considerations for corridor and community dc fast charging complex system design," US Department of Energy, pp. 1–51, May 2017.
- [11] S. Madhusoodhanan, A. Tripathi, D. Patel, K. Mainali, A. Kadavelugu, S. Hazra, S. Bhattacharya, and K. Hatua, "Solid-state transformer and MV grid tie applications enabled by 15 kV SiC igbts and 10 kV SiC mosfets based multilevel converters," *IEEE Transactions on Industry Applications*, vol. 51, no. 4, pp. 3343–3360, July 2015.
- [12] R. Y. Chen, T. J. Liang, J. F. Chen, R. L. Lin, and K. C. Tseng, "Study and implementation of a current-fed full-bridge boost dc-dc converter with zero-current switching for high-voltage applications," *IEEE Transactions on Industry Applications*, vol. 44, no. 4, pp. 1218–1226, July 2008.
- [13] S. Jalbrzykowski and T. Citko, "Current-fed resonant full-bridge boost dc/ac/dc converter," *IEEE Transactions on Industrial Electronics*, vol. 55, no. 3, pp. 1198–1205, March 2008.
- [14] C. Jung, "Power up with 800-V systems: The benefits of upgrading voltage power for battery-electric passenger vehicles," *IEEE Electrification Magazine*, vol. 5, no. 1, pp. 53–58, March 2017.
- [15] A. F. Hoke, M. Shirazi, S. Chakraborty, E. Muljadi, and D. Maksimovic, "Rapid active power control of photovoltaic systems for grid frequency support," *IEEE Journal of Emerging and Selected Topics in Power Electronics*, vol. 5, no. 3, pp. 1154–1163, Sept 2017.