

A Multi-Channel LED Driver with Selective Dimming

Ye Cikai*, Pritam Das[†], Sahoo Sanjib Kumar* and Majid Pahlevaninezhad[‡]

*Department of Electrical and Computer Engineering, National University of Singapore, Singapore

[†]Department of Electrical and Computer Engineering, Binghamton University, SUNY, NY, USA

[‡]Department of Electrical and Computer Engineering, University of Calgary, Canada

Abstract—A multi-channel LED driver consisting of front-end AC-DC boost Power Factor Correction (PFC) converter followed by a DC-DC power conversion stage with selective dimming capability for LED based lighting is proposed in this paper. Selective dimming of groups of output channels of a multi-channel LED driver comprising of a symmetric half bridge non-resonant DC-DC converter, high frequency transformer and symmetric voltage multiplier output rectifier with purely capacitive output is accomplished. The proposed driver has the advantages of low device count, high efficiency and can handle high power. Primary switches control the peak current of primary side which is proportional to LED peak current. The brightness based on average current of each group LEDs is controlled by duty ratios of four secondary switches, respectively. In this paper, the proposed selective dimming multi-channel LED driver is analyzed and validated on a 150W test setup.

I. INTRODUCTION

There has been a growing impetus to reduce energy consumption in urban buildings so as to reduce the related pollution of environment [1]. This has led to research and development of “NET ZERO Buildings” wherein a building or a group of buildings will produce their own energy from renewable energy sources (solar, etc [2]) installed on site and will have highly energy efficient smart appliances which are operated optimally so as to reduce electrical power demand [3]. One of the key electrical loads in buildings is lighting. It constitutes about 10%~12% of the total electrical loads in a commercial building.

It has been found that LEDs (typically 180 lumens per watt [4]) are three times more efficient than Compact Fluorescent Lamps (CFL) (50~70 lm/W [5]) in converting electrical energy to light and also their disposal is easier than mercury filled CFL lamps. Optimized lighting with LED, precisely conforming to the exact needs for lumens in a certain zone in a building depending on available natural light and occupancy and other factors can significantly reduce the electrical energy demands for lighting. Also, LEDs can operate up to 100,000 hours, equivalently 10 years. Added to that is the ease of dimming of LEDs. LEDs require DC current for their operation, so available electrical energy from the utility mains or renewable energy needs to be converted into a constant current source. This is where lies the importance in developing the power electronics involved in driving LEDs.

Multi-channel LED drivers have the advantages of high efficiency and low device count compared to single-channel

LED drivers for large area lighting applications. In some applications, the LEDs connected to different channels of a multi-channel driver are required to operate at different brightness. In such applications, a multi-channel LED driver with selective dimming of its channels presents a cost effective solution. One commercial application for the LED drivers with the requirement of selective dimming is shown in Fig. 1. According to the indoor illumination design application, the illumination in a room prefers to keep at 500~600 lux. Therefore, the lamps installed near the window (Lamp4 in Fig. 1) should supply less brightness than the lamps installed away from the window (Lamp1) to save energy. However, four LED lamps are supplied by one LED driver, and hence it requires the LED driver to have the function of selective dimming for different groups of LED channels.

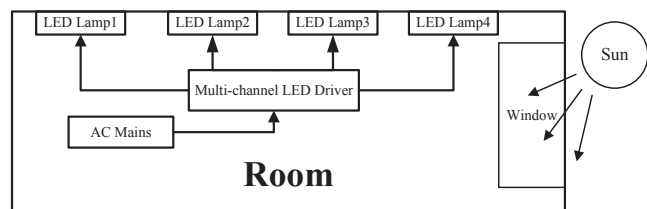

Fig. 1. Selective dimming multi-channel LED driver application

There are some solutions for multi-channel LED drivers with selective dimming proposed in [6]–[11]. One conventional method is to use multi LED drivers for each LED channel respectively to achieve selective dimming [6]. This reduces the driver efficiency compared to multi-channel LED drivers because of multiple energy conversion stages. Also, it increases the total size and cost since a large number of active and passive components are needed for separate control of converters at the input of every LED channel. Typically the efficiency of the LED drivers ranges from 75% to 85% only. This is due to the fact that the power converter topologies used in these drivers are based on single switch isolated DC-DC converters like the flyback converter [7] along with secondary side active switching devices, needed to operate at high switching frequency comparable to the primary side devices. This results in reduced overall efficiencies of such flyback converter based drivers.

Some non-isolated selective dimming LED drivers [8], [9] are only available for low power and low voltage applications. However, for high power LED drivers, galvanic isolation is needed and hence one more isolated stage of power conversion has to be added leading to increased cost and reduced efficiency. Some isolated resonant DC-DC selectively dimmed LED drivers are proposed in [10], [11]. A switched capacitor based selective dimming LED driver presented in [10] uses non-resonant DC-DC stage for isolation and each pair of channels of LEDs can achieve selective dimming. However, it needs four diodes, one MOSFET, one filter inductor and several capacitors on the secondary side of DC-DC stage for each pair of channels. An isolated Quasi-two-stage (PFC and resonant DC-DC) selective dimming LED driver [11] uses two secondary side DC buses obtained from resonant DC-DC stage for LED current and dimming control. However, an auxiliary Buck-Boost stage including one buck-boost control chip, one filter inductor, one MOSFET and one diode, has to be added for each channel to achieve the selective dimming.

In this paper, a new topology for multi-channel LED driver with selective dimming of output channels is proposed. The proposed topology is based on a non-resonant multi-channel equivalent dimming LED driver [12] with the advantages of high power and efficiency, complete soft switching of all high frequency switched semiconductor devices, reduction in power conversion stage, inherent protection against LED failures for both electrically open and short circuit conditions of the LEDs. In this topology, selective dimming is achieved for groups of output channels of a multi-channel LED driver comprising of a symmetric half bridge DC-DC converter, high frequency transformer and symmetric voltage multiplier output rectifier with purely capacitive output. This topology has the advantages of low device count, high power and high efficiency (>92%).

II. PROPOSED TOPOLOGY

Fig. 2 shows the block diagram of the proposed selective dimming multi-channel LED driver. This LED driver has AC Mains input, that can vary from 90Vac to 265Vac. The AC Mains passes through a rectifier and PFC boost circuit which accomplishes input power factor correction (PFC) and also boosting input AC to 400V DC output voltage. This DC voltage feeds a housekeeping flyback converter with an isolated 12VDC output for LDO. The function of the LDO is to produce a 3.3VDC for MCU supply. Another function of the 400VDC is powering the isolated non-resonant DC-DC converter. In this part of the circuit, the 400VDC bus is converted to a high frequency bi-polar AC waveform by properly gating ON and OFF the MOSFET devices in the transformer primary side. This high frequency AC voltage is incident across the primary of the high frequency transformer that provides galvanic isolation of the output LEDs from the input AC mains. The secondary side rectifier rectifies the secondary side high frequency AC current to drive LED loads. The control of primary MOSFET switches depends on the peak of the transformer primary current which is proportional

to the LED current, and the control of secondary MOSFET switches depends on the reference of average LED currents.

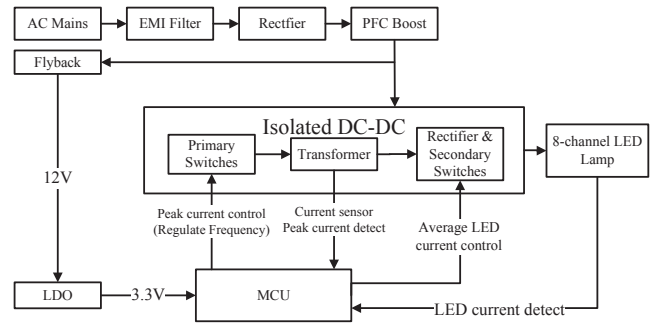

Fig. 2. Block diagram of proposed selective dimming multi-channel LED driver

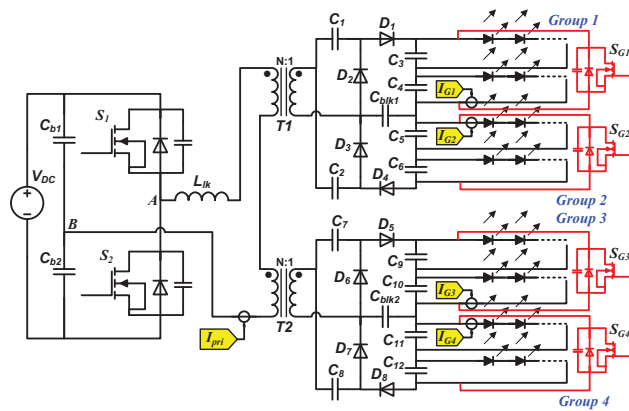

Fig. 3. Proposed selective dimming isolated DC-DC topology

The proposed selective dimming isolated DC-DC topology is shown in Fig. 3. This topology uses a symmetric half bridge non-resonant DC-DC converter, two high frequency transformers $T1$ and $T2$ to control the brightness of each of the four groups of LED channels selectively by switching ON and OFF four MOSFETs S_{G1} , S_{G2} , S_{G3} & S_{G4} on the secondary side. The secondary side devices will be operated at the frequency of PWM dimming which is much less than the switching frequency of primary side devices. This reduces the switching loss of the secondary devices significantly. Primary side MOSFETs S_1 & S_2 is used to control the peak current I_{pp} in the primary side by sampling the primary current I_{pri} and hence the peak current of LEDs. Secondary side MOSFETs aim to control the average current of each group of LEDs by sampling each group's LED current I_{G1} , I_{G2} , I_{G3} & I_{G4} respectively.

According to Fig. 3, for the primary side of the transformers $T1$ and $T2$, the 400V DC bus V_{DC} is from the output of PFC boost circuit. Due to the capacitors C_{b1} and C_{b2} of equal capacitances, the voltage across them is about $V_{DC}/2$. When the switch S_1 is ON and S_2 is OFF, the voltage $V_{AB} = V_{DC}/2$. In this situation, the transformer primary current increases due to the positive voltage across the combined leakage inductance

of the transformer primary. When S_1 is OFF and S_2 is ON, the voltage the voltage $V_{AB} = -V_{DC}/2$. In this situation, the current reduces due to the negative voltage. After the current reduces to zero, it will ramp in the negative direction. As a result of this charging and discharging of the primary leakage inductor L_{lk} , energy is transferred from the primary side to secondary side of the transformers. The rectifiers (symmetric voltage quadrupler) at the secondary side will rectify the high frequency AC current to drive the LED loads. It should be noted that each switch is ON for half of the total switching cycle. By changing the frequency of the gating waveform of the switches S_1 and S_2 , the peak current of primary side of the transformers $T1$ and $T2$ is varied, which leads to the variation in the energy transferred through the transformers and hence the average current fed to the output LEDs whose light intensity can hence be varied. For example, by increasing the frequency of switches S_1 and S_2 , the charging time of the primary inductor reduces. As a result, the peak of the transformer primary current reduces and hence the average LED currents reduce, and vice versa.

For the secondary side of the transformers $T1$ and $T2$, the LED currents of four groups of LED channels are controlled by four MOSFETs S_{G1}, S_{G2}, S_{G3} & S_{G4} , respectively. For example, when S_{G1} is ON, the LEDs of Group 1 will be OFF, and when S_{G1} is OFF, the LEDs of Group 1 will be ON. Similarly, the MOSFETs S_{G2}, S_{G3} & S_{G4} control the brightness of the LEDs of Group 2, 3 & 4, respectively. Based on the control of secondary MOSFETs S_{G1}, S_{G2}, S_{G3} & S_{G4} , the average currents of groups of LED channels to be dimmed simultaneously are sensed and fed back to the controller which controls the duty ratio of the gating pulses of the secondary MOSFETs to realize selective dimming for four different groups of LEDs.

The key advantages of the above mentioned selective dimming multi-channel LED driver are:

- 1) Truly single DC-DC stage converter which reduces additional active and passive devices resulting in reduced cost and increased electrical efficiency
- 2) The unique non-resonant energy conversion by energizing and de-energizing the high leakage inductance of the frequency transformer results in globally asymptotic stability of the converter.
- 3) Wide load range ZVS of primary side devices will be realized using the extremums of the transformer primary current
- 4) The converter will always operate in the lagging current mode wherein the zero crossings of the transformer primary current will always lag those of the output voltage at the output of the half-bridge converter.
- 5) No high voltage DC blocking capacitor is necessary due to symmetry of the half bridge used here
- 6) Selective dimming of each group of LED channels with LED peak current control

III. PRIMARY PEAK CURRENT ANALYSIS

The primary current with two specific situations of selective dimming is analyzed in this section.

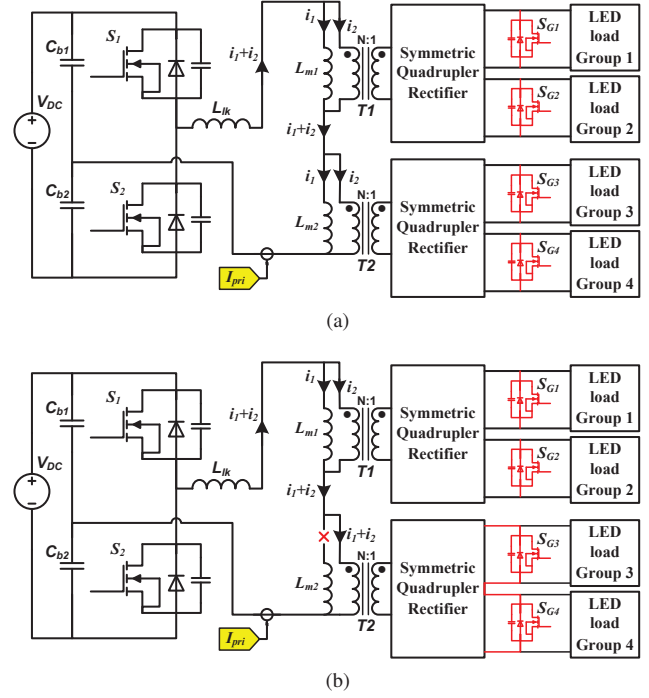

Fig. 4. Primary current analysis (a) four groups of LEDs ON (b) two groups of LEDs ON

When all secondary MOSFETs S_{G1}, S_{G2}, S_{G3} & S_{G4} are OFF, the structure of high frequency transformers $T1$ and $T2$ can be analyzed as Fig. 4(a), and Equation (1)-(4) can be obtained.

$$i_1 + i_2 = \frac{1}{L_{lk}} \int V_{L_{lk}} dt \rightarrow i_{1p} + i_{2p} = \frac{V_{L_{lk}} T_s}{L_{lk}} \frac{T_s}{4}$$

$$\rightarrow V_{L_{lk}} = \frac{4L_{lk}(i_{1p} + i_{2p})}{T_s} \quad (1)$$

$$i_1 = \frac{1}{L_{m1}} \int V_{L_{m1}} dt \rightarrow i_{1p} = \frac{V_{L_{m1}} T_s}{L_{m1}} \frac{T_s}{4}$$

$$\rightarrow V_{L_{m1}} = \frac{4L_{m1}i_{1p}}{T_s} \quad (2)$$

$$i_1 = \frac{1}{L_{m2}} \int V_{L_{m2}} dt \rightarrow i_{1p} = \frac{V_{L_{m2}} T_s}{L_{m2}} \frac{T_s}{4}$$

$$\rightarrow V_{L_{m2}} = \frac{4L_{m2}i_{1p}}{T_s} \quad (3)$$

$$V_{L_{lk}} + V_{L_{m1}} + V_{L_{m2}} = \frac{V_{DC}}{2}$$

$$\rightarrow \frac{4}{T_s} [L_{lk}(i_{1p} + i_{2p}) + L_{m1}i_{1p} + L_{m2}i_{1p}] = \frac{V_{DC}}{2} \quad (4)$$

where i_1 is primary current through magnetization inductor of transformers $T1$ & $T2$, i_2 is primary current proportional

transferred to second side of transformers, $i_1 + i_2$ is primary current through transformers, i_{1p} is peak value of i_1 , i_{2p} is peak value of i_2 , L_{lk} is total primary leakage inductance of both two transformers $T1$ & $T2$ and series connected inductor inductance, L_{m1} is magnetization inductance of transformer $T1$, L_{m2} is magnetization inductance of transformer $T2$ and $L_{m1} \approx L_{m2}$, $V_{L_{lk}}$ is voltage of L_{lk} , $V_{L_{m1}}$ is voltage of L_{m1} , $V_{L_{m2}}$ is voltage of L_{m2} , T_s is switching period of S_1 & S_2 and $T_s = 1/f_{SW}$, V_{DC} is 400VDC Bus from PFC boost circuit. The primary current of transformers $T1$ & $T2$ increases from zero to peak in quarter period. Within this quarter period, the primary voltage between two transformers keeps constant as $\pm V_{DC}/2$ according to the switching state of S_1 & S_2 .

One specific dimming case, shorted LED channels of Group 3&4, is presented in Fig. 4(b). According to Fig. 4(b), in the situation of MOSFETs S_{G1} & S_{G2} turning OFF and S_{G3} & S_{G4} turning ON, the voltage of secondary side of Transformer $T2$ is close to zero, because MOSFETs S_{G3} & S_{G4} lead to short of secondary side circuit of Transformer $T2$. As a result, $V_{L_{m2}}$ is closed to zero and hence there is no current through L_{m2} . Therefore, Equation (5)-(8) can be obtained.

$$i_1 + i_2 = \frac{1}{L_{lk}} \int V_{L_{lk}} dt \rightarrow i_{1p} + i_{2p} = \frac{V_{L_{lk}} T_s}{L_{lk}} \frac{1}{4} \rightarrow V_{L_{lk}} = \frac{4L_{lk}(i_{1p} + i_{2p})}{T_s} \quad (5)$$

$$i_1 = \frac{1}{L_{m1}} \int V_{L_{m1}} dt \rightarrow i_{1p} = \frac{V_{L_{m1}} T_s}{L_{m1}} \frac{1}{4} \rightarrow V_{L_{m1}} = \frac{4L_{m1}i_{1p}}{T_s} \quad (6)$$

$$V_{L_{m2}} = 0 \quad (7)$$

$$V_{L_{lk}} + V_{L_{m1}} + V_{L_{m2}} = \frac{V_{DC}}{2} \rightarrow \frac{4}{T_s} [L_{lk}(i_{1p} + i_{2p}) + L_{m1}i_{1p}] = \frac{V_{DC}}{2} \quad (8)$$

Comparing Equation (4) and (8), it can be found that if remaining the switching frequency f_{SW} of devices S_1 & S_2 constant, which means T_s is constant, both i_{1p} and i_{2p} will increase when MOSFETs S_{G1} & S_{G2} are OFF and S_{G3} & S_{G4} are ON. Meanwhile, $V_{L_{lk}}$ and $V_{L_{m1}}$ will also increase, and $V_{L_{m2}}$ is close to zero. Therefore, when MOSFETs S_{G1} & S_{G2} are OFF and S_{G3} & S_{G4} are ON, in order to maintain i_{2p} constant, one solution is to reduce T_s , which implies increasing the switching frequency f_{SW} of devices S_1 & S_2 .

IV. CONTROL METHOD

The control method aims to keep the peak current of each group of LEDs equal when all secondary MOSFETs are OFF. It is essentially done by control of duty ratio of S_{G1} , S_{G2} , S_{G3} & S_{G4} switched at a frequency f_{SG} much lower than the switching frequency f_{SW} of devices S_1 & S_2 while f_{SW} will be varied when some of secondary MOSFETs or

all of them are OFF. For this topology, control of two sides (Transformer primary side and secondary side) should be considered to realize selective dimming for four groups of LEDs.

A. Primary peak current control

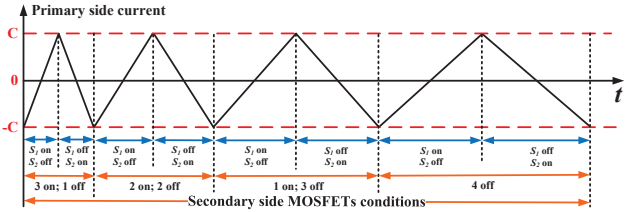

Fig. 5. Primary peak current control

It should be noted that the repetitive single-pulse over-current events in LEDs may result in a shortened life expectancy or early catastrophic failure of the LEDs [13]. Hence, it is important to control the peak current of LEDs. The primary peak current control aims to maintain the peak current at the primary side of transformers $T1$ & $T2$ at a constant value and so will be the peak current of each group of LEDs when they are ON. In this control method, switching frequency f_{SW} of S_1 & S_2 is varied depending on the peak current at the primary side of transformers $T1$ & $T2$. Fig. 5 shows the primary peak current control method. The switching frequency f_{SW} of devices S_1 & S_2 increases with the shorted groups of LEDs increasing as analyzed before. For example, the switching frequency f_{SW} is higher when three secondary MOSFETs are ON and one secondary MOSFET is OFF than the switching frequency when one secondary MOSFET is ON and three secondary MOSFETs are OFF. The primary peak current is set at a constant value C . When S_1 is ON and S_2 is OFF, the primary current of transformers $T1$ & $T2$ increases due to the positive voltage across the combined leakage inductance L_{lk} of the transformer primary. Once this current arrives to C , the states of S_1 & S_2 are changed so that S_1 is turned OFF and S_2 is turned ON. In this condition, primary current reduces due to the negative voltage. After this current reduces to zero, it will increase in the negative direction. Once this negative current arrives to $-C$, the states of S_1 & S_2 are changed again. In this state, the primary current increases to zero and to be a positive. Once it arrives to C again, the states of S_1 & S_2 will be changed.

With this primary peak current control, the peak of transformer primary current is maintained at a constant value C and hence peak current in every LED channel will be constant when they are in the ON state. Therefore, average current of each group of LEDs can be varied depending on duty ratio of MOSFETs S_{G1} , S_{G2} , S_{G3} & S_{G4} respectively. Note that secondary switching frequency f_{SG} is much lower than primary switching frequency f_{SW} , and LED peak current depends on the constant C .

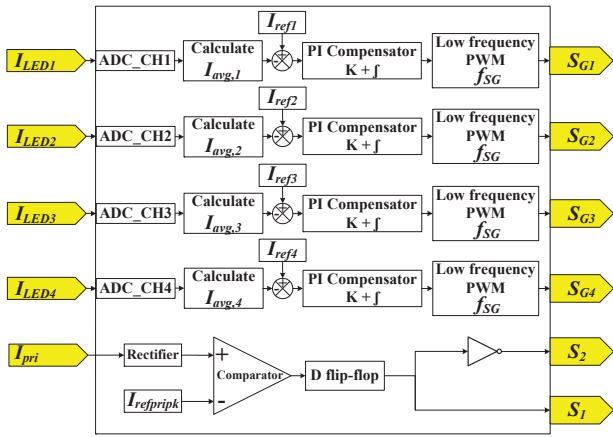

Fig. 6. Control method of primary and secondary switches

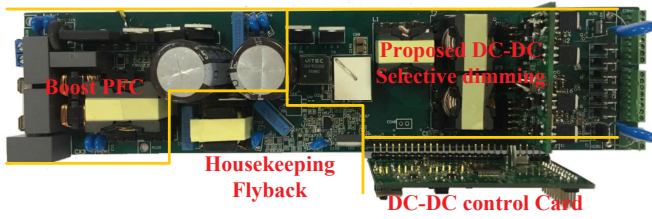

Fig. 7. Prototype of the LED driver with selective dimming

B. Secondary LED average current control

The secondary LED average current control aims to keep sampled average currents of four groups of LEDs the same as their respective reference values. Currents in each group of LED channels are sensed using resistive sensing and fed back to the controller. According to the primary peak current control, i_{2p} is constant, and hence the peak current of each group of LEDs will remain constant when they are in the ON state. Therefore, the average currents of each group of LEDs are shown in Equation (9).

$$I_{avg,i} = (1 - D_i)k_m i_{2p} \quad (9)$$

where $i = 1, 2, 3, 4$, $I_{avg,i}$ is LED average current of Group 1, 2, 3&4 respectively, D_i is the duty ratio of MOSFETs S_{G1}, S_{G2}, S_{G3} & S_{G4} respectively, k_m is proportional coefficient between i_{2p} and peak current of LEDs in the ON state.

According to Equation (9), $i_{avg,1}, i_{avg,2}, i_{avg,3}$ & $i_{avg,4}$ are proportional to respective D_1, D_2, D_3 & D_4 since k_m and i_{2p} are constant. Hence, the average current of each group of LEDs varies based on the secondary MOSFETs S_{G1}, S_{G2}, S_{G3} & S_{G4} duty ratios.

Based on the analysis in primary and secondary switches control, the detailed control of both primary and secondary switches is described in Fig. 6, where $I_{LED1}, I_{LED2}, I_{LED3}$ & I_{LED4} are respective sampled currents of LED Groups 1, 2, 3&4, $I_{ref1}, I_{ref2}, I_{ref3}, I_{ref4}$ are respective reference values of average currents of LED Groups

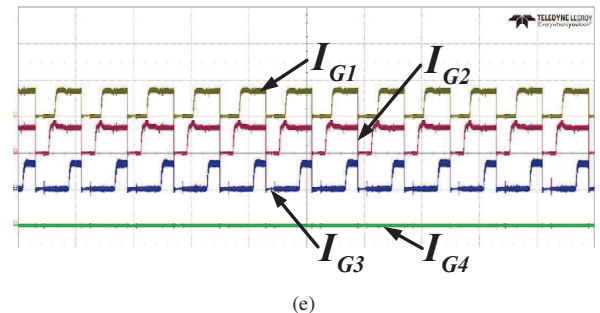
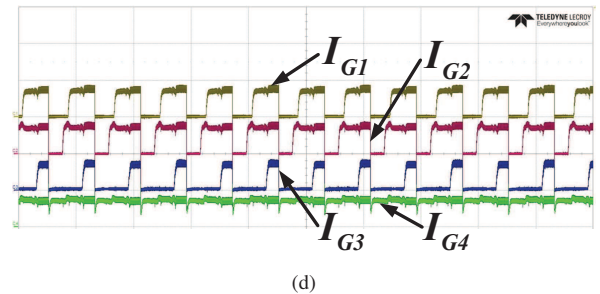
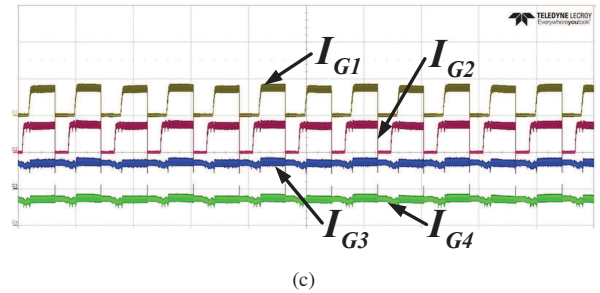
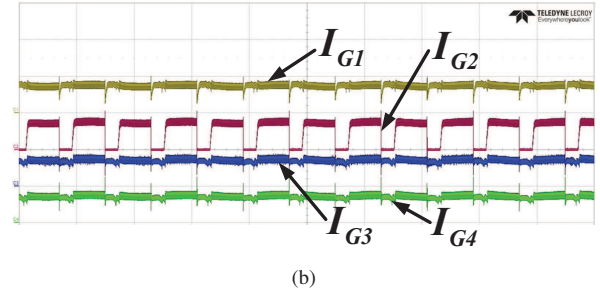
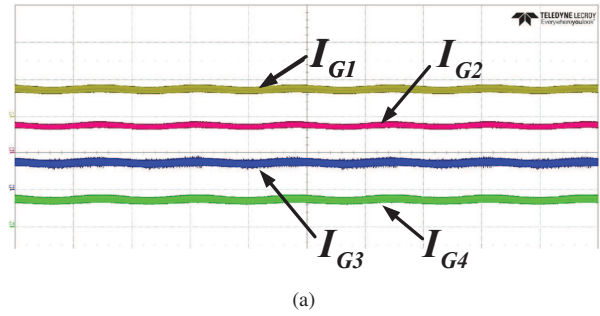

Fig. 8. Waveforms of four groups of LED currents (a) No dimming (b) Selective dimming of one group of LED channels (c) Selective dimming of two groups of LED channels (d) Selective dimming of three groups LED channels (e) Selective dimming of four groups LED channels (LED current:0.5mA/div, t :5ms/div)

1, 2, 3&4, $I_{refpripk}$ is the reference value of primary peak current. In the experiments, the LED average currents $I_{avg,i}$ is obtained by sampling I_{G1}, I_{G2}, I_{G3} & I_{G4} respectively.

As a summary of this control method, the primary peak current control aims to keep the peak current of each group of LEDs constant when they are in the ON state, and secondary LED average current control aims to vary the average current of each group of LEDs according to the duty ratios of the secondary MOSFETs S_{G1}, S_{G2}, S_{G3} & S_{G4} . The goal of this control method is that the peak current in each of the group of LEDs is constant and the average current in each of the group of LEDs will be maintained at the respective reference values.

V. EXPERIMENTAL RESULTS

An experimental prototype multi-channel LED driver with selective dimming, universal single-phase AC input and maximum output power of 150W is implemented. Fig. 7 shows the prototype of the selective dimming LED driver. It is implemented along with input boost PFC converter by TI UCC28180D and DC-DC selective dimming by microcontroller ST STM32F103RBT6.

Fig. 8 shows the waveforms of four groups of LED currents. Fig. 8(a) shows the LED currents without dimming. Fig. 8(b) shows the one group of LED channels with selective dimming. The average current of Group 2 is controlled to 250mA. Fig. 8(c) shows the two groups of LED channels with selective dimming. The average currents of Group 1 and Group 2 are controlled to 200mA and 250mA, respectively. Fig. 8(d) shows the three groups of LED channels with selective dimming. The average currents of Group 1, Group 2, Group 3 are controlled to 200mA, 250mA, 100mA, respectively. Fig. 8(e) shows the four groups of LED channels with selective dimming. The average currents of Group 1, Group 2, Group 3 are controlled to 200mA, 250mA, 100mA, respectively, and Group 4 of LEDs is OFF. In different selective dimming conditions of Fig. 8(b)-(e), the peak currents of each group of LEDs keep equal to the condition without dimming in Fig. 8(a).

VI. CONCLUSION

In this paper, selective dimming of groups of output channels of a multi-channel output LED driver comprising of a symmetric half bridge DC-DC converter, high frequency transformer and symmetric voltage multiplier output rectifier with purely capacitive output is presented. The groups of output channels of LEDs can operate at different brightness with a cost effective and energy efficient solution. The detailed hardware design, transformer primary and secondary switching operation control method have been described. The experiment on a laboratory prototype validates the proposed converter with 230V grid input and 150W output.

ACKNOWLEDGMENT

We thank Associate Professor Ho Ghim Wei for the assistance. This work is supported by the National Research Foundation Singapore, Ministry of National Development (MND), R-263-000-C22-277.

REFERENCES

- [1] J. Zhao, "Greenhouse gas abatement analysis of the energy saving retrofit in pulverized coal power plants," in *Power and Energy Engineering Conference (APPEEC), 2010 Asia-Pacific*. IEEE, 2010, pp. 1–4.
- [2] W. Zghal, G. Kantchev, and H. Kchaou, "Determination of the exploitable solar energy for electricity generation using the photovoltaic systems," in *Renewable Energies and Vehicular Technology (REVET), 2012 First International Conference on*. IEEE, 2012, pp. 43–48.
- [3] S. Mukherjee, "Opportunities and challenges with net zero energy buildings," in *Power Semiconductor Devices and ICs (ISPSD), 2011 IEEE 23rd International Symposium on*. IEEE, 2011, pp. 1–5.
- [4] "Cree LED datasheet," [Online] Available: <http://www.cree.com/led-components/media/documents/XLampXBD.pdf>.
- [5] "Compact fluorescent lamp (CFL) - wikipedia," [Online] Available: https://en.wikipedia.org/wiki/Compact_fluorescent_lamp.
- [6] C.-L. Chu, T.-L. Chiu, and K.-H. Chen, "Pseudo zero-dimension dimming for power reduction in field sequential color liquid crystal display systems," *Journal of Display Technology*, vol. 6, no. 8, pp. 323–331, 2010.
- [7] S.-Y. Wang, C.-L. Tseng, S.-C. Lin, S.-C. Wang, C.-L. Chen, and J.-H. Chou, "Design and implementation of a single-stage high-efficacy LED driver with dynamic voltage regulation," in *Systems, Man, and Cybernetics (SMC), 2013 IEEE International Conference on*. IEEE, 2013, pp. 1438–1443.
- [8] A. Zhao and W. T. Ng, "An energy conservation based high-efficiency dimmable multi-channel LED driver," in *Energy Conversion Congress and Exposition (ECCE), 2011 IEEE*. IEEE, 2011, pp. 2576–2580.
- [9] Z.-Z. Yang, Y.-H. Liu, P.-Y. Chen, and J.-W. Huang, "Sequential-color voltage-adaptable RGB-LED backlight driving system with local dimming control for LCD panels," in *Power Electronics and Drive Systems, 2009. PEDS 2009. International Conference on*. IEEE, 2009, pp. 1542–1546.
- [10] J. Liu, W. Sun, and J. Zeng, "Precise current sharing control for multi-channel LED driver based on switch-controlled capacitor," *IET Power Electronics*, vol. 10, no. 3, pp. 357–367, 2017.
- [11] T. Jiang, J. Zhang, K. Sheng, and Z. Qian, "High-efficiency quasi-two-stage converter with current sharing for multi-channel LED driver," in *Future Energy Electronics Conference (IFEEC), 2013 1st International*. IEEE, 2013, pp. 311–315.
- [12] R. Kathiresan, P. Das, T. Reindl, and S. K. Panda, "Novel high-power nonresonant multichannel LED driver," *IEEE Transactions on Industrial Electronics*, vol. 64, no. 7, p. 5851, 2017.
- [13] "Pulsed Over-Current Driving of Cree Xlamp LEDs: Information and Cautions," [Online] Available: <http://www.cree.com/led-components/media/documents/XLampPulsedCurrent.pdf>.