

Multiple Conversion Ratio Resonant Switched-Capacitor Converter with Active Zero Current Detection

Eli Hamo, Alon Cervera, and Mor Mordechai Peretz

Power Electronics Laboratory, Department of Electrical and Computer Engineering
Ben-Gurion University of the Negev

P.O. Box 653, Beer-sheva, 84105 Israel. <http://www.ee.bgu.ac.il/~pel/eliham@walla.com>; cervera@bgu.ac.il; morp@ee.bgu.ac.il

Abstract— This paper introduces an active method for zero current switching (ZCS) for resonant switched capacitor converters (SCC) with wide dynamic range. The method is demonstrated on a Binary SCC that features wide range of conversion ratios. Due to the resultant high efficiency of the converter operating under soft-switching conditions, it is applicable for higher power levels up to the medium power range (100W). The resonant operation is achieved with single air core inductor and precise commutation at zero current. The sensing signals of the resonant currents are obtained from the flying capacitors rather than from the inductive element in which the current includes a dc component. The zero detection method developed is capable of compensating for both the processing delays (from detection to switching action) and for the large variations of the resonant characteristics (due to transition between sub-circuits) and for any other component variations. A prototype with maximum input voltage of 100V and 19 conversion ratios was built and tested experimentally. The current sensing was implemented with a simple, cost-efficient, passive, sensor. For proper construction of the higher power experimental prototype, a simple and efficient, isolated gate driver was also developed.

I. INTRODUCTION

Switched capacitor converters (SCC) are becoming an attractive alternative in many applications ranging from low to high power. These include voltage regulators for mobile electronic systems, voltage equalizers for batteries and capacitors, for photovoltaic (PV) modules, and for automotive applications [1-4].

The efficiency of an SCC linearly depends on the proportionality between the output voltage and the target voltage V_o/V_{Target} [5-8], where $V_{Target}=MV_{in}$ and M is the no-load voltage transfer ratio. High efficiency can be reached if M is widely controllable with high resolution. The generic equivalent circuit model for SCC [9], describes the losses by an equivalent resistance connected at the output of the SCC- R_{eqT} . Hence, the efficiency can be expressed as:

$$\eta = V_o / V_{Target} = R_o / (R_o + R_{eqT}) . \quad (1)$$

An effective way to realize many target voltages is the Binary/Fibonacci SCC that exhibits a widely controllable

conversion ratio [7]. The benefits of resonant operation with this converter have been demonstrated in [10].

Soft switching in resonant converts can be obtained by switching the transistors at zero current. Given that the resonant frequency depends on the tank's physical parameters – C, L and R, the switching times can be either calibrated in advance to match the resonant frequency, or a control circuit can be implemented to identify zero crossing. For the case of conventional resonant converters, Zero Current Switching (ZCS) operation and its implementation have been widely demonstrated [11-15]. For the case of resonant SCC however, few topologies have been proposed e.g. [2-4]. A methodological approach to obtain ZCS for the entire dynamic range of the SCC has not been reported hitherto.

The main problem of pre-calibrating resonant switched capacitor converters for zero current switching is that the physical parameters of the system are prone to drifts throughout the operation range. This is particularly crucial in resonant SCC circuits since the inductance is often implemented by the stray inductance of the circuit which may vary by design and from one sub-circuit to another while the capacitance values drift as a function of bias voltages and temperature. Hence, an active zero current cross detection circuitry is required to compensate for all inaccuracies and uncertainties of the parameters, and to assure zero current switching operation.

Another challenge for sensing the current in resonant SCC is the dc component of the resonant current. In this case, the signal is not centered around zero and requires additional processing for zero detection. This can be done using rather costly active sensors or by resistive elements alongside with very high gain-bandwidth op-amps [16-19].

The objective of this study is to introduce an active ZCS method for resonant SCC, and to apply it on a resonant Binary/Fibonacci SCC. The resultant converter has a wide range of conversion ratios with high efficiency that can be applied in higher power applications. The diagram of Fig. 1 shows the system configuration of the active ZCS converter. A resonant Binary/Fibonacci SCC is implemented by adding

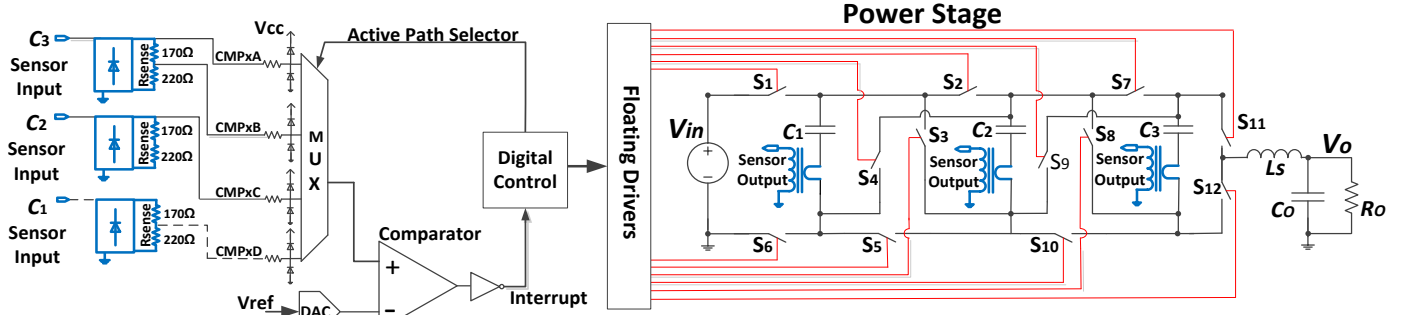

Fig. 1: Resonant SCC scheme showing the current sensors and analog comparator for zero cross detection.

an inductance at the output of the converter. The converter is capable for either step-up or step-down conversions depending on the source-load orientation. That is, step-up conversion can be obtained by swapping the input and output.

For simplicity and without losing generality, the active ZCS method is demonstrated and explained for Binary SCC case.

II. THE RESONANT BINARY/FIBONACCI SCC

The precursor of the converter of Fig. 1 is the hard-switched Binary/Fibonacci step-down SCC [5-7], which is capable of generating multiple fractional conversion ratios with Binary and/or Fibonacci resolution. For a case of three flying capacitors ($n=3$), the converter is capable of producing 19 levels of conversion ratios with high efficiency [7]. To achieve a desired fractional conversion ratio, a specific switching sequence that interconnects the flying capacitors with summing or subtracting action to the source and the output, is applied. For example, a conversion ratio of $M=5/8$, requires Extended Binary (EXB) codes that are translated to five sub-circuits as illustrated in Fig. 2. Following the switching sequence, the average voltages across the flying capacitors and the output voltage will adjust to: $V_{C1}=(1/2)V_{in}$, $V_{C2}=(1/4)V_{in}$, $V_{C3}=(1/8)V_{in}$, $V_{Co}=(5/8)V_{in}$. Since solution is unique [6], control is not required to assure that the capacitors have stabilized at their nominal voltages. The voltages of the flying capacitors hold the same average value for any conversion ratio available using the EXB code.

Resonant operation with sinusoidal current can be obtained by relying on the stray inductances that exist in the conduction path of each sub-circuit. This approach may be impractical in applications where the switching frequency is limited (by the generator or drive losses) [2-4]. A more practical approach that is applied in this study is to introduce a single air-core inductor, L_s , in series to the output stage [2-4, 10]. By doing so, the same (dominant) inductance is affecting all sub-circuits (Fig. 2). Transition between switching states (sub-circuits) under Zero Current Switching (ZCS) conditions can be carried out either by manual timing of the switching period of each state, or by an active ZCS, that is, measuring the resonant current, detecting a zero current level, and then toggling the switches to the next sub-circuit sequence. Since the resonant characteristics, i.e. the natural frequency and quality factor, of the sub-circuits may vary significantly because of

different interconnections of the capacitors, as well as stray inductances, an active method is essential to assure ZCS. This approach will also compensates for any parameter variations or drifts due to changes in the operating conditions.

The contribution of each flying capacitor to the average output current (for $M=5/8$) may be derived from the equivalent RCL circuits of Fig. 2. Under steady-state operation, charge balance of all capacitors is satisfied (i.e. average current equals zero). The sum of the currents for each state I_1 - I_5 , and the sum of all currents, can be expressed as:

$$\begin{cases} 0 - I_2 + I_3 - I_4 + I_5 = 0; & C_1 \\ -I_1 + I_2 + I_3 + 0 + 0 = 0; & C_2 \\ -I_1 - I_2 - I_3 + I_4 + I_5 = 0; & C_3 \\ I_1 + I_2 + I_3 + I_4 + I_5 = I_o; & \end{cases}, \quad M = 5/8. \quad (2)$$

where the currents I_j are average currents of each subcircuit (averaged over the entire switching period).

Table I summarizes the expected currents for various conversion ratio that were obtained by solving a set of equations similar to (2). In each case k_j is the proportional coefficient between the average current of the flying capacitor and output current for state j , namely, $I_j = k_j I_{out}$. Duality can be observed between ratios $1/8$ to $7/8$, and $3/8$ to $5/8$.

The results of Table I indicate that for a given subcircuit the average currents vary considerably between the switching state and in some cases, negative current may exist in one of the states. This implies however, that for some conversion ratios, one of the states, in fact, discharges the output capacitor. The extra circulating current will of course increase the losses. The variability of the average currents between the states adds extra burden to the zero detection circuitry.

TABLE I.
SOLUTIONS OF THE AVERAGE CAPACITOR CURRENTS FOR VARIOUS RATIOS.

M	Proportional Coefficient				
	k_1	k_2	k_3	k_4	k_5
1/8	1/8	1/8	1/4	1/2	--
3/8	-1/8	3/8	1/2	0	1/4
5/8	1/4	3/8	-1/8	0	1/2
7/8	1/2	1/4	1/8	1/8	--

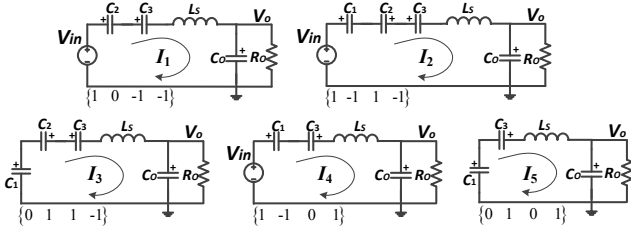

Fig 2: Resonant SCC sub-circuits configured from the EXB codes of $M=5/8$.

To illustrate the operation of the resonant SCC, typical currents and voltages waveforms, are depicted in Fig. 3 for the case of $M=5/8$. It can be observed that the average currents of the flying capacitors is zero, their voltages are stabilized, and that the DC output current is built up by the contribution of all sub-circuits that, in turn, are connected to the load for half a resonant period. The portion of negative current is also observed.

III. PRACTICAL IMPLEMENTATION

To realize cost-effective resonant operation for the SCC of Fig. 1, that is, to obtain soft-switching of *all switches for all transitions between sub-circuits*, the following challenges need to be addressed:

- The seemingly natural current sensing point, the series inductance to the output, contains a dc component.
- The resonant characteristics (natural frequency and quality factor) are considerably different from one sub-circuit to another. This is due to different interconnections of the flying capacitors according to the EXB code (e.g. Fig. 2).
- Uncertainties and variations of the parameters (inductance and capacitance) may be very large. Especially for different operating conditions (conversion ratio and power levels).
- The average and the peak current are not constant for each sub-circuit and for a given state at different power ratings.
- Zero current detection at the crossing point is impractical due to poor signal-to-noise (SNR) ratio and the time delay from detection to commutation of the switches. Selection of the reference depends on the above arguments.

To overcome these challenges, a zero current detection and control circuitry was developed in this study and is schematically described in Fig. 1. It includes a current sensor for each of the flying capacitors, comparator module, microcontroller, and decoders. The transition between switching states of the EXB code is governed by comparing the resonant currents to specified references. These are discussed in this section which also addresses issues of limiting the inrush current, stabilizing the capacitors' voltages after startup, and the realization of simple and efficient floating gate drivers of the power switches.

A. Current sensing and zero crossing detection

To eliminate the need for a rather costly, active current sensing circuitry that accommodates dc current, passive

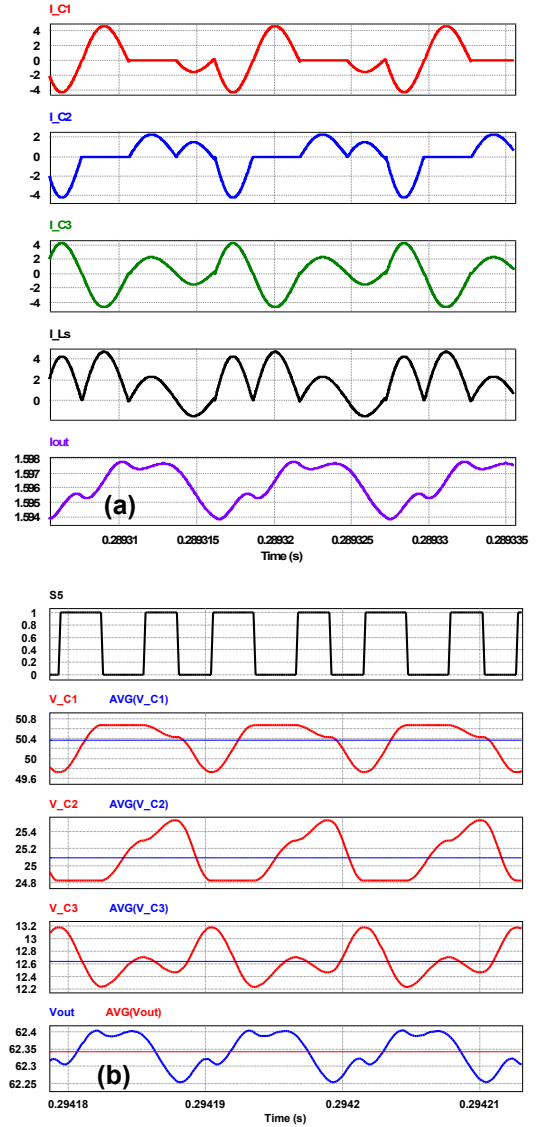

Fig. 3: Resonant Binary SCC (a) Capacitors and output stage current waveforms. (b) Capacitors and output voltages waveforms. PSIM Simulations set-up at: $M=5/8$, $V_{in}=100V$, $P_{out}=100W$, $L_s=200nH$, all flying capacitors $C_j=9.4\mu F$, and $f_s=90kHz$.

magnetic current transformers are placed on all three flying capacitors.

Since the aim of the current sensing is the detection of the zero crossing point rather than regulation, the dc component of the current is not of interest. The reason for the apparent redundancy in the current measurements is that there is no single capacitor that participates in all the states for all voltage ratio configurations. In the example shown in Fig. 2 of $5/8$, C_3 participates in all the states, but for other ratios such as $2/8$ it is omitted. By having three sensors, current can be read from any active capacitor.

A comparator module that is integrated in a microcontroller was utilized in this work for current detection. Since the comparator is a part of the IC and prohibits negative voltages, the sensed current was first rectified and then converted to a proportional voltage using

a resistor R_{sense} . To protect the I/O ports of the digital controller and since only the information in the vicinity of zero current is of interest, the rectified signal is clamped to the voltage rails by diodes. The series resistor is used to limit the current to the controller. By taking these measures of precaution, the resistor R_{sense} can be selected to the worst-case for the state of the lowest current.

At steady-state, switching command is initiated by the analog comparator module. The comparator output triggers an auxiliary interrupt upon zero detection in which the switching state of the next sub-circuit is applied on the transistors, and if required, changes the path selector of the MUX for next state.

B. Reference Voltage

As mentioned above, the comparator reference voltage cannot be zero since finite response time, t_d , exists in the control system – i.e. delay time from detection to actual switching action. The reference voltage is set to compensate for t_d and for the slope of the sensed current [20]. Fig. 4 shows typical difference between two state pulses being sensed. Assuming a high quality factor ($Q > 3$), the reference voltage, as a function of the resonant peak and time duration can be expressed as:

$$V_{ref_j} = \frac{I_{m_j}}{n} \sin \left(2\pi \left[\frac{1}{2} - \frac{t_d}{t_{oj}} \right] \right) R_{sense}, \quad (3)$$

where n is the current transformer winding ratio, I_{m_j} is the flying capacitors currents, t_{oj} is the resonant period, and $j \in \{1, 2, 3, 4\}$ is state indicator. The peak value of the sensed signal is translated into voltage by $V_{mj} = (I_{m_j}/n) R_{sense}$.

The slope of the sensed current depends on the circuits' resonant frequency and peak currents, and varies from one sub-circuit to another. Variable reference voltage would assure accurate ZCS at every switching instance. However, this requires an extremely fast control loop to obtain the information of the state current on-the-fly [21]. To avoid this complexity, a compromise is made based on the expected variations in the currents due to the operation in different sub-circuits and parameters variations. It allows setting of a constant reference voltage with the penalty of mismatch in the switching with respect to the zero crossing point. Considering an extreme worst-case slope variation as depicted in Fig. 4 of 400% increase in peak current and 200% increase in resonant period, and that t_d is approximately $0.1t_{oj}$, the ratio between the nominal reference voltage (V_{ref2}) and the worst-case reference (V_{ref1}) can be obtained using (3), that is:

$$\frac{V_{ref_1}}{V_{ref_2}} = \frac{\frac{4I_{m_1}}{n} \sin \left(2\pi \left[\frac{1}{2} - \frac{0.1t_{o1}}{t_{o1}} \right] \right) R_{sense}}{\frac{I_{m_2}}{n} \sin \left(2\pi \left[\frac{1}{2} - \frac{0.1t_{o1}}{2t_{o1}} \right] \right) R_{sense}} = 2.025, \quad (4)$$

which translates into an absolute maximum mismatch in the switching time of $0.1t_{oj}$. Provided that the operation of each sub-circuit is in the range of microseconds, the result of (4)

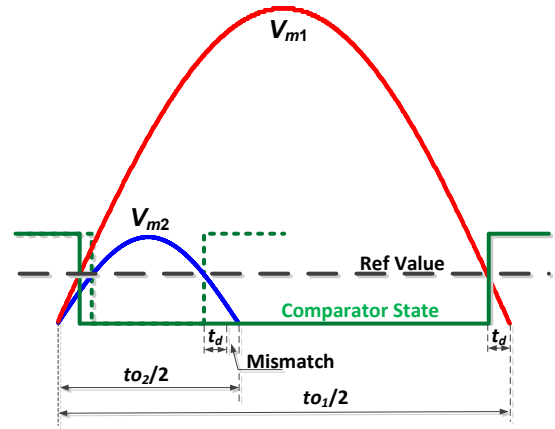

Fig. 4: Worst-case conditions of state current variation and the mismatch of the switching instance due to fixed reference settings.

implies a small deviation from the true zero crossing point, allowing the use of a fixed reference voltage.

In this work, the reference voltage and the sensing gain are selected such that the true ZCS is obtained at higher power levels (higher states' currents), and the small mismatches in the ZCS will be at lower power levels. To allow operation in wide range of power levels and input voltage variations and still work in the vicinity of ZCS, a coarse tuner to switch between operation ranges is realized. The scaling of the sensing gain is implemented by voltage dividers branching out to the MUX (Fig. 1).

Another consideration when setting a low reference value is the need to avoid the ground noise caused by imperfect switching at nonzero, common-mode, etc. that may result in erroneous triggering of the comparator. This is overcome by a blanking period of the comparator after switching action, as done in many commercial current sensing oriented applications.

C. Stabilizing the flying capacitors voltage on startup

The design of the active ZCS method and circuitry assumes that the voltages of all capacitors have stabilized to their nominal values (binary fractions). Applying the above zero detection method (demonstrated in detail in the next section), assures that at steady state ZCS is realized for all conversion ratios and over a wide operation range of input voltage and power levels. In a practical turn on situation, the capacitors' voltages are zero. This results in high inrush currents if the converter is allowed to operate in the vicinity of the steady-state resonant frequency. Moreover, relying on the comparator to trigger commutation is impractical since the inrush current profile may not be of a resonant nature. To remedy this, a voltage-stabilizing and current-limiting sequence is required to limit the flying capacitors current to a safe value and to bring the flying capacitors voltage to their steady-state value.

In this study, as shown in Fig. 5, a voltage-stabilizing and current-limiting method that is based on the operation of the Binary converter is applied. The concept is to rely on the EXB codes to assure stabilization of the capacitors' voltages

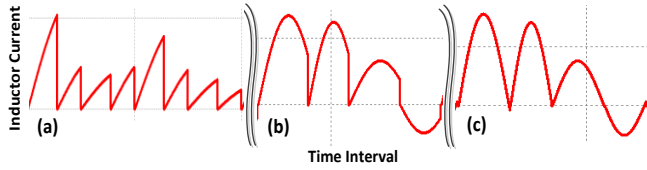

Fig 5: Conceptual operation of the soft start sequences for $M=3/8$ (resonant current): (a) high-frequency switching; (b) estimated resonant values; (c) active ZCS method.

to the correct values, and to limit the inrush current by controlling the switching frequency, this is done as follows: At startup the switching times are made significantly shorter than the resonant period such that the peak current does not exceed a set maximum value. This is done for few cycles until the voltage across the capacitors has stabilized. Then, a second switching sequence that is adjusted to the estimated resonant values is applied for few cycles to ease the transition to active current sensing. At the end of this phase, the ZCS circuitry is activated and transition between sub-circuits is governed by the comparator output.

D. Switches and Isolated Gate Drivers

To facilitate all the interconnections of the flying capacitors as prescribed in the EXB codes [5-7] for all conversion ratios, the converter includes twelve four-quadrant switches (Fig. 1). Each switch is realized by two N-channel power MOSFETs with the gate and sources interconnected as depicted in Fig. 6.

Proper design of that allows operation at high input voltages requires isolated gate drivers. As depicted in Fig. 6, the gate driver structure used in this study consists of a 1:1 pulse transformer for isolation, a dc blocking capacitor C_1 to prevent the dc content of the gate drive from passing through the pulse transformer, C_2 and D_2 to restore the dc level at the secondary side, capacitor C_3 that acts as independent floating supply, and NPN and PNP transistors connected in a push-pull configuration.

Assuming that the voltages across C_2 and C_3 are stable, the operation of the gate driver may be described as follows: on State: V_p is positive, D_1 is forward biased and C_3 partially discharges through Q_1 that is saturated, and charges C_{GS} turning on the MOSFET. Then, C_3 recharges through C_2 and D_1 . The independent supplier C_3 provides a quick charging of C_{GS} and therefore, the rise time is relatively fast off state: V_p is negative, D_2 is forward biased, C_2 now charges in the opposite direction through D_2 . C_{GS} discharges through Q_2 that is saturated, turning off the MOSFET. R_2 damps potential overshoots that may occur due to stray inductances. The experimental floating drivers have shown the capabilities to operate at the switching frequency range of 30kHz-350kHz, wide duty cycle range of 0.1-0.9, and rise and fall times of approximately 200ns.

IV. EXPERIMENTAL RESULTS

To demonstrate the performance of the resonant Binary SCC and the operation of the active zero current switching, a 100W prototype has been built and tested experimentally. Summary of the system components can be found in

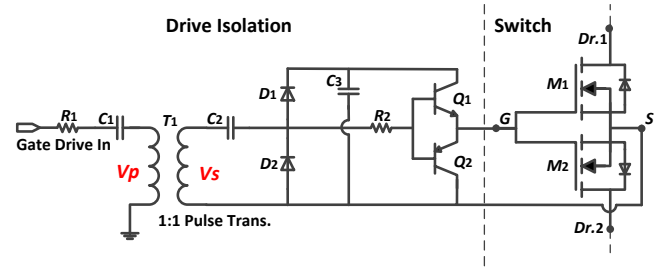

Fig. 6: Isolated Gate Driver and four-quadrant switch using N-channel power MOSFETs.

Table II. The generation of the EXB codes has been realized on a dsPIC33F series microcontroller. Due to the large number of I/O ports required for the power switches, an auxiliary decoder is used. The microcontroller selected includes an analog comparator module and a multiplexer to allow selection of the input feed. The comparator module features high-speed operation with a typical delay of 20ns and a typical offset voltage of $\pm 5mV$. However, a typical delay of the zero detection system, from comparator detection until the time that an interrupt is triggered was measured to be 500ns. The total processing time (from comparator to switches commutation) was found to be approximately 1 μs . Following the design guidelines above, the worst-case resonant frequency (highest value) per state is set to 180kHz to allow sufficient processing time. The reference voltage to the comparator is set to 1.65V to compensate for the processing time delay and improve the SNR of the detection. Performance of the system and the ZCS method developed is demonstrated on operation with the conversion ratios of 1/8, 3/8, 5/8, and 7/8 to cover the entire operation range. For each of the conversion ratios, the capability of the method to lock the switching frequency to the resonant frequency is verified for wide range of line (30-80V) and load variations (20-130W). For the conversion ratios of 3/8 and 5/8, the current has been sensed from C_3 that is active at all sub-circuits and the peak currents from one state to another are of the same order. For the case of 1/8, the current levels significantly vary between sub-circuits, therefore, the feed to the comparator has been switched between C_3 and C_2 . A larger R_{sense} is chosen for C_2 to successfully detect the zero crossing point at lower currents. For 7/8, to cover the full power range of 130W, the current is sensed from top of the resistive ladder (390 Ω) of C_3 for lower power range (up to 70W), and is then switched manually to the voltage division point (220 Ω) to measure higher power levels up to 130W. The measurement circuitry (sensors, dividers, etc.) is detailed in Fig. 1.

Fig. 7 shows exemplary snapshots of the system operating at steady-state with active ZCS for four conversion ratios tested. As described in the practical implementation section and can be observed from Fig. 7, large differences exist between the sub-circuits in the peak currents, quality factors, and the signals' slopes at the vicinity of zero current. Minor glitches in the current shapes are the result of small deviations between the estimated reference voltage and the experimental signal.

To verify the operation of the active ZCS method, two sets of experiments have been carried out. In the first

experiment, the load resistance is kept constant while the input voltage varied from 30V to 80V. Active ZCS is obtained for the entire operation range and all conversion ratios. Fig. 9 shows the efficiency curves of the converter as a function of the output power for each of the conversion ratios. It can be observed that, as expected from the theory of SCC, the efficiency is virtually constant for a given load resistance.

The strength of the active ZCS is highlighted in Table III, which summarizes the average values of equivalent resistance and efficiency, and the deviation (in percentage) of the duration of each sub-circuit. As described earlier and can also be observed Fig. 7, the conduction time of the sub-circuit varies from one to another, this is primarily due changes in the overall capacitance. Moreover, Table III indicates that the duration of a specific sub-circuit may also vary considerably due to changes in components values for different operating conditions, strongly promoting the necessity of an active method for zero detection. The largest variations in components' values are expected in wider conversion ratios such as 1/8. There, larger rms currents are needed per-unit of transferred power which affects the capacitance and inductance within a sub-circuit. The larger rms currents are also the reason for the somewhat lower efficiency in spite of the lower equivalent resistance obtained for this ratio.

In the second experiment, the input voltage is kept constant at 80V while varying the load. Active ZCS is obtained for the entire operation range and all conversion ratios. Fig. 10 shows the efficiency curves of the converter as a function of the output power for each of the conversion ratios. Similarly to the previous experiment, the efficiency is nearly constant for a wide operation range. It should be noted however, that in the case of 1/8, a narrower power range is examined due to practical constraints on the stress of the components. The power range for each conversion ratio that is covered in this experiment has been intentionally limited due to practical restrictions. That is, the experiment is conducted such that the maximum current stress on the flying capacitors does not exceed 4Arms.

The startup sequence that was described earlier is also demonstrated on the experimental setup. Fig. 8 shows the three operation modes used limit the inrush currents and stabilize the capacitors' voltages, that is, operation with EXB code at: (a) high frequency; (b) estimated times; (c) activating the active ZCS mode and locking the switching frequency to the resonant frequency.

V. DISCUSSION AND CONCLUSIONS

An active zero current switching method that allows resonant operation of Binary and Fibonacci step-up/down switch-capacitor converter was developed and tested experimentally. For high-frequency resonant operation, the stray inductances of the circuit can be used. To lower the frequency of operation, and by doing so to ease the workload requirements of the digital processor and allow the use of a simple, low-cost controller, a single air-core inductor in series to the output stage, was added.

The active zero current cross detection was found to accurately adjust the switching times for four different RCL sub-circuits dictated by the EXB/SFN codes. The current sensing mechanism was implemented using three current transformers strategically mounted after the capacitors to avoid measurement of the output current that includes a dc component.

The major challenge in the design of a resonant Binary SCC is the significant variation in switching times that is required for soft-switching operation. This variation is present when switching between one sub-circuit to another which may involve different number of capacitors in series, and therefore, changes the resonant period. Another source for different resonant periods is that the capacitance and inductance values are strongly dependent on the operating conditions. This means that the time period of a given sub-circuit is not constant for variations in the power level or the input voltage, and rules out any non-instantaneous ZCS or pre-calibrated resonant operation. The experimental validation confirmed that conjecture and highlighted the advantages of an active method. It revealed that the changes in the resonant period within a sub-circuit are significant and may vary up to 30% for the operation range tested. It has also been established that although the resonant periods vary considerably, the slope of the sensed current in the vicinity of the zero crossing point is less prone to variations.

TABLE II.
CONVERTER PARAMETERS

Component	Power Stage	
	Part No.	Value
Input capacitor	C5750X7R2A475K	6 x 4.7 μ F/100V
Output capacitor	C5750X7R2A475K	10 x 4.7 μ F/100V
Flying capacitor	C5750X7R2A475K	3 x 4.7 μ F/100V
MOSFETs (R_{Dson})	IPA030N10N3	2 x 3m Ω
Air Inductor	Air core	2.1 μ H
Microcontroller	dsPIC33FJ16GS502	
Current Transformer	FXC -TN16/9.3/6.3 (Ferrite toroid)	1:100
Digital Section		
Microcontroller	dsPIC33FJ16GS502	16bit, 40MIPS
Decoder	MC745HC139A	
Floating Driver		
Driver	MIC4427	
Pulse Transformer	GT03-111-110-A	1:1
Transistor (Q_1)	JE181	
Transistor (Q_2)	JE170	
Diodes (D_1, D_2)	1N914	

TABLE III.
MEASUREMENTS WITH ACTIVE ZCS FOR CONSTANT

M	R_{out} [Ω]	R_{eqT} [Ω]	η_{AV}	ΔV_{in} [V]	ΔI_{out} [A]	Δt_{s1} [%]	Δt_{s2} [%]	Δt_{s3} [%]	Δt_{s4} [%]
1/8	2.5	0.37	0.847	56.8	2.37	28.6	25	23.2	13.8
3/8	16	1.05	0.925	58.6	1.27	25	2.5	2.4	21.5
5/8	29.3	1.01	0.958	36.5	0.74	1.4	30	10	1.4
7/8	36.5	0.42	0.979	24.1	0.57	7.7	25	3.2	14.3

Δx – Indicates the amount of variation in a measured variable x value throughout the experiment.

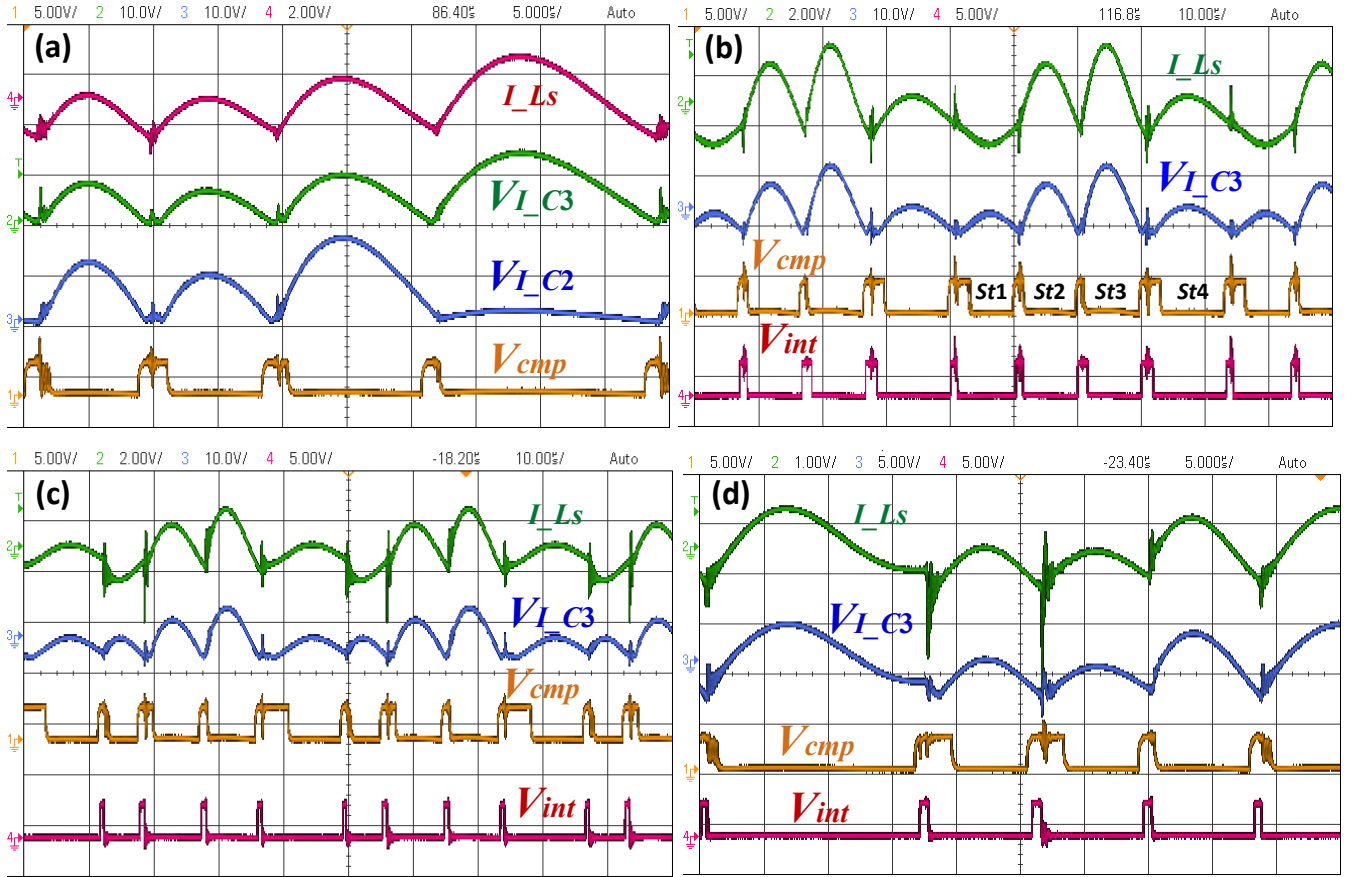

Fig. 7: Experimental result of the Binary converter operating in active ZCS mode for various conversion ratios. (a) $M=1/8$, $V_{in}=80\text{V}$, $P_{out}=31.3\text{W}$, $\eta=0.85$; Traces top to bottom: inductor current I_{Ls} (0.8A/div), rectified sensed voltage resulting from I_{C3} , V_{Ic3} (10V/div), rectified sense voltage resulting from I_{C2} , V_{Ic2} (10V/div), comparator output, V_{cmp} (5V/div). Horizontal scale (5 μs /div). (b) $M=3/8$, $V_{in}=100\text{V}$, $P_{out}=76.5\text{W}$, $\eta=0.92$; Traces top to bottom: I_{Ls} (0.8A/div); V_{Ic3} (10V/div); V_{cmp} (5V/div); interrupt status V_{int} (5V/div). Horizontal scale (10 μs /div). (c) $M=5/8$, $V_{in}=80\text{V}$, $P_{out}=73\text{W}$, $\eta=0.95$. Traces and horizontal scale: as in (b). (d) $M=7/8$, $V_{in}=80\text{V}$, $P_{out}=131.7\text{W}$, $\eta=0.99$. Traces top to bottom: I_{Ls} (0.4A/div), V_{Ic3} (5V/div); V_{cmp} (5V/div); V_{int} (5V/div). Horizontal scale (5 μs /div).

Therefore, for the case of the Binary SCC, the method can be further simplified by fixed reference voltage settings. This eliminates the need for additional fast compensation loop to vary the reference voltage.

The experimental results also support the need for a dynamic wide-range reference voltage in order to compensate for processing delay and different current levels of each sub-circuit. Since a reasonable SNR is required, the reference to the comparator was kept constant (well above zero) and the reference was changed by the effective sensing gain. This was done by resistor dividers of the sensed signal and may be useful for implementation in other resonant switch capacitor topologies.

Study on the efficiency was carried out. It was found that although the calculated [9] equivalent resistance is the lowest at the ratio of 1/8, that ratio provides the poorest efficiency. Moreover, the efficiency increases for smaller conversion ratios (larger fractions). This behavior is intuitively explained by the fact that higher ratios (such as 1/8, 3/8) have higher rms current for a given transferred power and hence the power losses will be higher. This can be illustrated

by rewriting (1) in the following form:

$$\eta = \frac{V_o}{V_r} = \frac{(V_o / I_o)}{(V_o / I_o + R_{eq})} \quad (5)$$

That is, since for a given power level, the load resistance of larger ratios (smaller fractions) such as 1/8 is significantly smaller the efficiency is expected to drop per-unit of transferred power. Another observation on the efficiency and the expected equivalent resistance is made by the current waveforms and from the solution for the average currents for each sub-circuit. It shows that for some conversion ratios, there might be a sub-circuit in which the current is negative. This phenomenon can be explained from a charge-balance perspective and is given in section II. However, from efficiency and R_{eqT} point of view, that means that for that particular sub-circuit, current flows from the output into the system which may affect the estimations of R_{eqT} and the expected efficiency. A detailed analysis of this topic is beyond the scope of this paper and will be detailed in subsequent publications.

The method presented in this study has been verified to successfully operate resonant Binary SCC and to accommodate wide and dynamic operation range, and

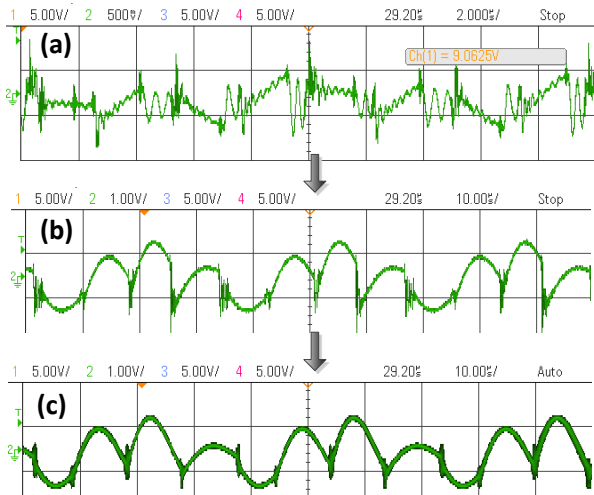

Fig. 8: Experimental results of the inductor current for the soft-start method for $M=3/8$: (a) High switching frequency; (b) estimated resonant values; (c) active ZCS method.

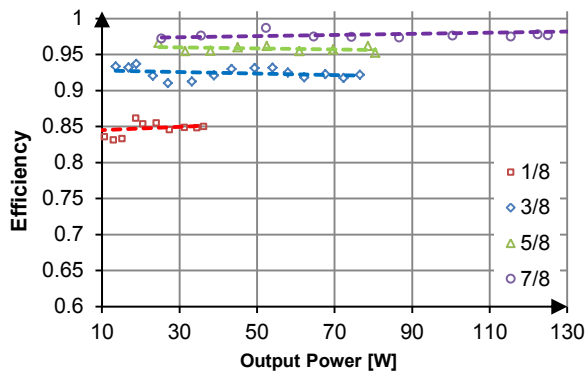

Fig. 9: Measured efficiency, $M=1/8-7/8$, constant R_o , $V_{in}=30-80V$.

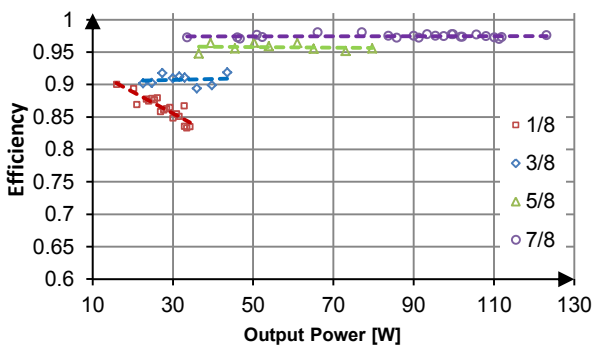

Fig. 10: Measured efficiency, $M=1/8-7/8$, constant $V_{in}=80V$.

therefore can be applied to other multi-phase SCC topologies that involve number of sub-circuits and wide operation range.

REFERENCES

- [1] A. Ioinovici, "Switched-capacitor power electronics circuits," *IEEE Circuits Syst. Mag.*, vol. 1, Issue 3, pp.37-42, 2001.
- [2] Fang Zheng Peng, Dong Cao, "A zero-current switching multilevel switched-capacitor dc-dc Converter," *IEEE Trans. on Industry Applications*, vol.46, no.6, 2011.
- [3] Fang Zheng Peng, Dong Cao, "Optimal design of multilevel modular switched-capacitor dc-dc converter," *IEEE Conf.- ECCE 2011*.
- [4] Dong Cao, Fang Zheng Peng, "A family of zero current switching switched-capacitor dc-dc converters," *IEEE Conf. - APEC 2010*, pp. 1365-1372.
- [5] S. Ben-Yaakov, A. Kushnerov, "Algebraic foundation of self adjusting switched capacitors converters," *IEEE Conf.- ECCE, sep. 2009*.
- [6] A. Kushnerov, S. Ben-Yaakov, "Algebraic synthesis of fibonacci switched capacitor converters," *IEEE Conf. - COMCAS, nov. 2011*.
- [7] A. Kushnerov, S. Ben-Yaakov, "Unified algebraic synthesis of generalized fibonacci switched capacitor converters," *IEEE Conf.- ECCE 2012*.
- [8] Y. Beck, S. Singer, "Capacitive transposed series-parallel topology with fine tuning capabilities," *IEEE Tran. On Circuits and System*, vol. 58, no.1, pp 51 – 61, 2011.
- [9] S. Ben-Yaakov, M. Evzelman, "Generic and unified model of switched capacitor converters," *IEEE Conf. - ECCE, 2009*.
- [10] E. Hamo, M. M. Peretz, S. Ben-Yaakov, "Resonant binary and fibonacci switched-capacitor bidirectional dc-dc converter," *IEEE Conf. 2012*.
- [11] Mishima, T. Nakaoka, "A new family of ZCS-PWM dc-dc converters with clamping diodes-assisted active edge-resonant Cell," *Inter. Conf. on Electrical Machines and Systems*, ICEMS 2010.
- [12] Chien-Ming Wang, Huang-Jen Chiu, "A family of zero-current-switching (ZCS) PWM converters using a new zero-current switching auxiliary Circuit," *International Conf. on Power Electronics and Drive Systems - PEDS*, vol. 2, pp. 1407-1412, 2003.
- [13] Ling Qin, Shaojun Xie, Hui Zhou, "A novel family of PWM converters based on improved ZCS switch cell," *IEEE Conf. - PESC 2007*, pp. 2725-2730.
- [14] Chien-Ming Wang, "Novel zero-current-switching (ZCS) PWM converters," *IEEE Conf. IECON 2003*, vol.1, pp. 391-396.
- [15] Chien-Ming Wang, "A new family of zero-current-switching (ZCS) PWM converters," *IEEE Transactions on Industrial Electronics*, vol. 52, no.4, pp. 1117-1125, August 2005.
- [16] Forghani-zadeh, H.P., Rincon-Mora, G.A., "Current-Sensing techniques for dc-dc converters," *Midwest Symposium on Circuits and Systems, MWSCAS-2002*, vol. 2, pp.II-577-II-580.
- [17] Zheng Luo, Chuanyun Wang, Ming Xu, Pengju Kong, Fred C. Lee, "Dcr current sensing technique for PFC circuits," *IEEE Conf. - APEC 2008*, pp. 1384-1388.
- [18] Panda, R.K., Sawade, N.A., "Air cored current sensor for digital metering & micro-processor based protection unit," *IEEE Conf. - Power India 2012*, pp. 1-6.
- [19] Y. N. Ning, Z. P. Wang, A. W. Palmer, K. T. V. Grattan, and D. A. Jackson, "Recent progress in optical current sensing techniques," *American Institute of Physics 1995*, pp. 3097-3111.
- [20] S. Ben-Yaakov, M. M. Peretz, "A self-adjusting sinusoidal power source suitable for driving capacitive loads," *IEEE Trans. on Power Electronics*, vol. 21, no.4, pp. 890-898, 2006.
- [21] E. Rotman, S. Ben-Yaakov, "Rapid push-pull resonant charger for high power high voltage application using low input voltage," *IEEE Conf. - ECCE, 2013*.